



# **SuperDim**<sup>®</sup>

A Triad<sup>®</sup> Brand

## **SuperDim<sup>®</sup> Analog Dimming**

Technical Product Information

# SuperDim® System Features

Universal Lighting's SuperDim® analog ballasts offer the most cost-effective solution for energy-saving requirements. Universal offers a wide variety of SuperDim ballasts for T5, T8, and CFL lamps.

## Features:

- SuperDim® ballasts provide reliable lighting control down to 3% for all applications
- Compatible with most 0–10V manufactured controls
- Combine with photocells for daylight harvesting
- Ideal for use with 0–10V energy management controls
- Programmed rapid start technology maximizes lamp life
- Low profile design for fixture design flexibility
- Universal input voltage (120–277V) for installation flexibility
- Starts at any level without flashing
- Control input protected against miswiring
- Single and multiple lamp versions are available in a variety of case configurations

## Dimming Controls and Accessories:

SuperDim ballasts are compatible with a wide variety of popular controls and photocells. A list of these control manufacturers is available at [www.unvlt.com](http://www.unvlt.com) in the energy management and controllable lighting section

*A list of SuperDim® ballasts and their applications is available on the Universal website at [www.unvlt.com](http://www.unvlt.com) in the energy management and controllable lighting section.*

# SuperDim® System Wiring

## Power Wiring

- If the SuperDim ballasts use the switched line from a control device, the maximum number of units depends on the current-carrying capacity of the switch
- SuperDim ballasts, and the luminaires in which they are mounted, must be properly grounded. Failure to do so will result in lamp flickering and other system malfunctions.
- Each SuperDim ballast housing must make good contact with the fixture chassis for proper operation. Use of a star washer or other means of paint penetration is recommended for this.
- Some ballasts are equipped with connectors. In these cases a grounding terminal is provided to facilitate the ballast-to- fixture connection.
- Make the required connections and properly cap off any unused wires.

## Control Wiring

- Do not connect the control wires to the branch circuit power conductors.
- Do not ground any of the control wires. This will cause intermittent operation of SuperDim ballasts.
- Polarity of control wiring must be maintained throughout the system for proper operation (purple-to-purple and gray-to-gray).

## SuperDim® System Installation

*Warning! SuperDim ballasts are to be wired according to their label diagrams and installed in accordance with national and local electrical codes.*

## Mounting

- SuperDim ballasts and modules must be mounted against a flat metal plate, which acts as a heat sink for the unit. Proper operation depends on good connection between ballast and fixture chassis. A star washer or other paint penetrating device is strongly encouraged.
- Leads for any particular ballast installation must not exceed the maximum lengths identified by its Application and Performance Specification.
- Fixtures equipped with SuperDim ballasts must maintain an internal ambient temperature less than or equal to 40°C, and must further maintain ballast case temperatures to within the limit expressed on its Application and Performance Specification.
- Fluorescent fixtures should not be mounted in areas with cool air drafts; this may result in uneven dimming caused by low lamp temperatures.
- Linear fixtures must incorporate a grounded lamp "starting aid". The spacing between lamp wall and starting aid (grounded fixture surface) must be between 1/8th and 1/2 inch.
- Lamps must not touch any grounded metal.
- Lamp support brackets (if used) must not be metal.

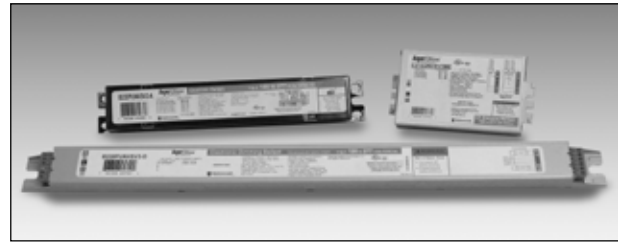

## Lamp Wiring

- A ballast-to-lamp wiring diagram is shown on each ballast label. These diagrams must be adhered to for proper lamp and ballast operation.
- Keep the lead lengths as short as practical, and do not tightly bundle the lamp wires.
- Maintain consistent lead lengths and wiring practices for all fixtures in a room.
- Some lamp manufacturers advise operating new lamps at full bright for at least 100 hours before dimming.
- Use the same lamp type in all fixtures (within a room) to avoid uneven light levels and inconsistent colors.
- Do not use instant start lamp sockets with SuperDim ballasts (see Figure 1).

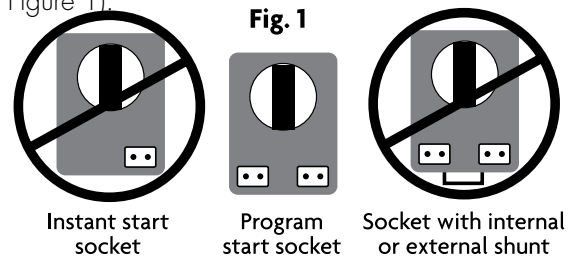

# SuperDim® Analog (0-10 volt) Dimming Ballasts

Application		SuperDim	System Watts (Max)		Input Amps (Max)		Ballast Factor (Max)	Case Style	Wiring Diagram
Lamp	No.	Ballast	120V	277V	120V	277V			
<b>T8 - Linear Fluorescent Lamps</b>									
F32T8	1	B132PUNVSV3-A	30	30	0.25	0.11	0.88	A	1
F25T8 (3ft)	1	B132PUNVSV3-A	22	22	0.18	0.08	0.85	A	1
F17T8	1	B132PUNVSV3-A	16	16	0.13	0.06	0.85	A	1
F32T8	2	B232PUNVSV3-A	57	56	0.48	0.20	0.88	A	2
F25T8 (3ft)	2	B232PUNVSV3-A	45	44	0.38	0.16	0.85	A	2
F17T8	2	B232PUNVSV3-A	32	32	0.27	0.12	0.85	A	2
<b>T5 - Linear Fluorescent Lamps</b>									
F35T5	1	B135PUNVSV3-D	40	39	0.33	0.14	1.00	D	3
F28T5	1	B128PUNVSV3-D	32	32	0.27	0.12	1.00	D	3
F21T5	1	B128PUNVSV3-D	25	25	0.21	0.10	1.01	D	3
F14T5	1	B114PUNVSV3-D	17	17	0.14	0.06	1.00	D	3
F28T5	2	B228PUNVSV3-D	63	61	0.53	0.22	1.00	D	4
F21T5	2	B228PUNVSV3-D	47	46	0.39	0.17	1.00	D	4
F14T5	2	B214PUNVSV3-D	32	32	0.27	0.12	1.00	D	4
<b>T4 - Compact Fluorescent Lamps</b>									
CFTR42W/GX24q	1	C226UNVSV3ME	42	42	0.35	0.15	1.00	CDIM	5
CFTR32W/GX24q	1	C226UNVSV3ME	34	34	0.28	0.12	1.00	CDIM	5
CFQ26W/G24q	1	C226UNVSV3ME	28	28	0.26	0.10	1.00	CDIM	5
CFTR26W/GX24q	1	C226UNVSV3ME	28	28	0.26	0.10	1.00	CDIM	5
CFQ26W/G24q	2	C226UNVSV3ME	53	53	0.44	0.19	1.00	CDIM	6
CFTR26W/GX24q	2	C226UNVSV3ME	53	53	0.44	0.19	1.00	CDIM	6
CFQ18W/G24q	1	C218UNVSV3ME	20	20	0.17	0.08	1.00	CDIM	5
CFTR18W/GX24q	1	C218UNVSV3ME	20	20	0.17	0.08	1.00	CDIM	5
CFQ18W/G24q	2	C218UNVSV3ME	39	38	0.33	0.15	1.00	CDIM	6
CFTR18W/GX24q	2	C218UNVSV3ME	39	38	0.33	0.15	1.00	CDIM	6
CFQ13W/G24q	1	C213UNVSV3ME	16	16	0.13	0.06	1.00	CDIM	5
CFTR13W/GX24q	1	C213UNVSV3ME	16	16	0.13	0.06	1.00	CDIM	5
CFQ13W/G24q	2	C213UNVSV3ME	30	30	0.25	0.11	1.00	CDIM	6
CFTR13W/GX24q	2	C213UNVSV3ME	30	30	0.25	0.11	1.00	CDIM	6

# Wiring Diagrams

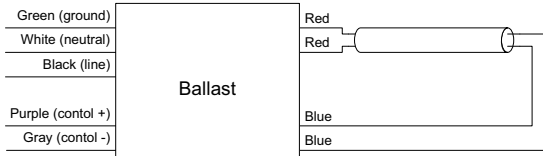

Wiring Diagram 1

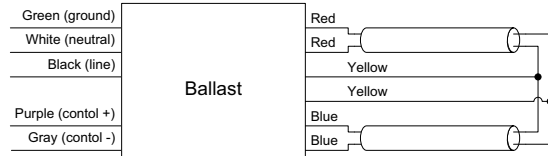

Wiring Diagram 2

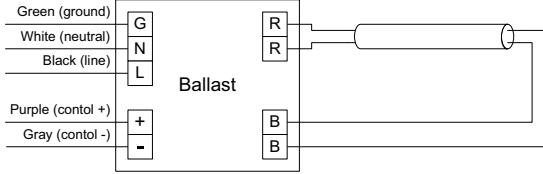

Wiring Diagram 3

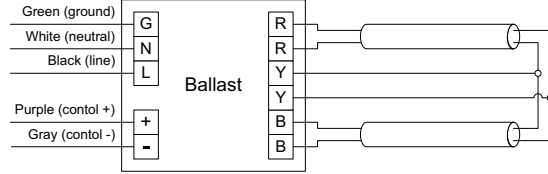

Wiring Diagram 4

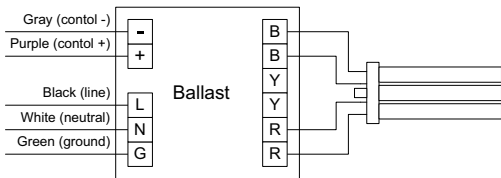

Wiring Diagram 5

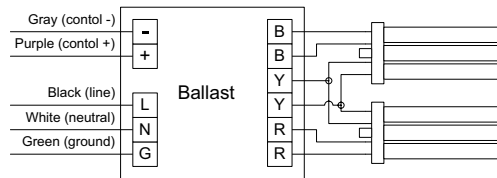

Wiring Diagram 6

## Case Styles

Dimensions in inches

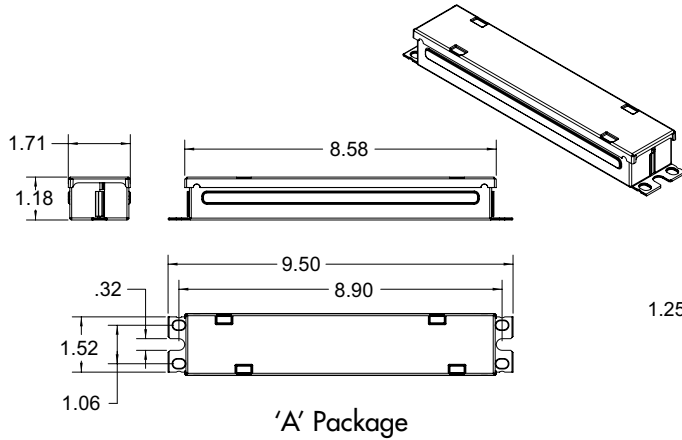

'A' Package

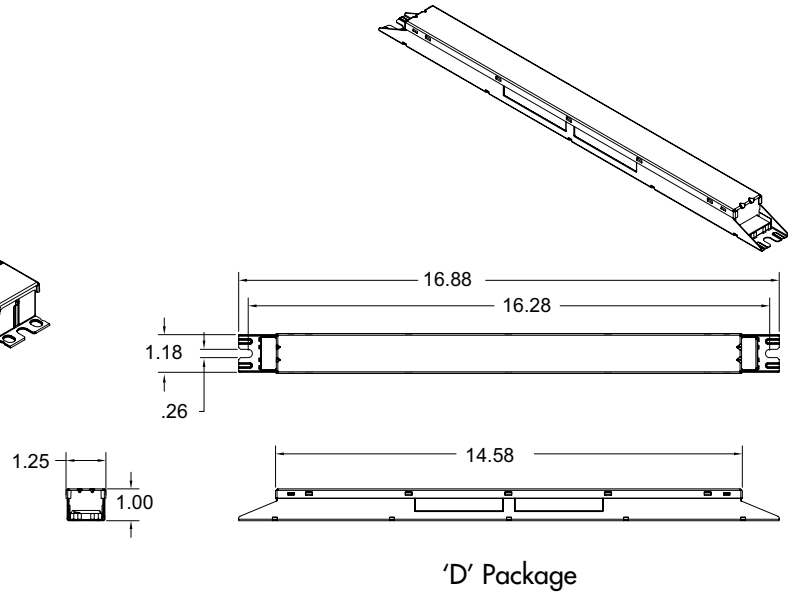

'D' Package

Fixtures for use with SuperDim ballasts must be equipped with non-shunted sockets. Lamp wiring must be done according to diagrams on ballast labels

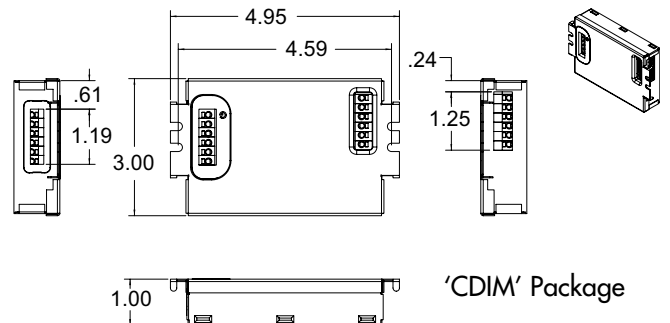

'CDIM' Package

# SuperDim System Verification

*Warning!! Ensure that all SuperDim devices are wired exactly as shown on the wiring diagram, and properly grounded properly before starting this step.*

Ballast functions should be checked before completing the installation job.

Conduct the following three verification steps to make sure the system is wired correctly and working properly:

- Verify ballast function, including power and lamp wiring
- Verify control wire installation and dimming function
- Verify control device operation

*Caution!! Before installing or troubleshooting any component, turn off AC power to prevent possible electric shock and equipment damage.*

## 1) Verify ballast function

1. After connecting power wires to the luminaires, but before making any control wire connections, apply power to the lighting circuit. All ballasts should strike their lamps and provide full intensity. If they fail to do so, check the troubleshooting section for guidance.
2. Disconnect power from the lighting circuit.

## 2) Verify control wiring & dimming function

1. Connect purple and gray control wires to all ballasts. Do not connect control wires to the lighting circuit power conductors. Do not connect the control device (wall station controller, photocell, etc.) to this circuit yet. Separately cap off all un-terminated wire ends.
2. Apply power to the lighting circuit. All ballasts should strike their lamps and operate at full intensity.
3. Remove power from the lighting circuit then connect the purple and gray wires together to form a short on the control circuit.
4. Reapply power to the lighting circuit. All SuperDim ballasts on the control circuit should strike their lamps and operate at minimum intensity.
5. If any of the ballasts behave differently, check and troubleshoot the control wiring. See the SuperDim troubleshooting section for more details if necessary.
6. Disconnect power and remove the short from the control circuit.

## 3) Verify control device options

1. Connect the control device and verify its function according to its manufacturer's instructions.

# SuperDim® Troubleshooting Guidelines

Note: All wiring must be completed in compliance with national and local electrical codes.

Caution!! Disconnect power before servicing ballasts, fixtures or other system components.

Symptom	Possible Reason	Action
<b>Lamps never turn ON, or lamps flash and then turn OFF</b>	Ballast not powered.	Check power wiring, luminaire disconnect, circuit breaker, etc.
	Ballast not properly grounded.	Fixture must be properly grounded, and ballast housing must have good electrical contact with metallic fixture chassis. Use of a star washer or other paint penetrating device is recommended for ballast mounting. Some ballasts provide a ground terminal as an alternative means to make this connection.
	Incorrect lamps.	Ensure lamp selection matches ballast capabilities.
	Lamp-ballast wiring error.	Ensure connections between ballast and lamps are exactly as shown on ballast label.
	Shunted sockets. SuperDim ballasts require non-shunted sockets, also known as rapid-start or program-start sockets.	Inspect or test lamp holders (sockets). With lamp removed and ballast disconnected, a shunted socket will always present a short circuit (zero ohms) between connections. Non-shunted sockets do not provide a connection (internal or external) between the blades.
	Poor starting aid. (not applicable to CFL models)	Ensure that a grounded metallic surface is within proper distance of the lamps. Spacing between the lamp wall and the grounded metallic surface should be between 0.125 and 0.500 in. for the entire length of the fluorescent tube. This requirement applies to linear fluorescents only.
	Defective lamps. Defective ballast.	Try lamp replacement. Try ballast replacement.
<b>Some or all fixtures stuck at minimum intensity</b>	Control wires at line potential.	Carefully inspect all connections. Control circuit must not be connected to power conductors.
	Controller not powered.	When unpowered, some controllers may force the control voltage to a low level resulting in minimum intensity operation. Check line, neutral and ground connections.
	Short circuit between control wires. Wrong polarity at one or more control circuit connection points.	Inspect control wiring for improper connections or damage resulting in a short-circuit condition. Inspect control wiring. Sound connections, and correct polarity must be maintained throughout the control circuit: purple-to-purple and gray-to-gray.
<b>Some or all fixtures stuck at maximum intensity</b>	Control wires disconnected.	Inspect control wiring for improper connections or damage resulting in an open-circuit condition.
<b>Ballasts do not respond to controller</b>	Wrong controller type.	Check control specification. Use only 0-10V control. Please see the controls compatibility chart on the SuperDim webpage for some typical examples of suitable 0-10V controls.
	Controller not powered.	Check line, neutral and ground connections.
	Control wires disconnected.	Inspect control wiring for improper connections or damage resulting in an open-circuit condition.
	Short circuit between control wires.	Inspect control wiring for improper connections or damage resulting in a short-circuit condition.
	Wrong polarity at one or more control circuit connection points.	Inspect control wiring. Sound connections, and correct polarity must be maintained throughout the control circuit: purple-to-purple and gray-to-gray.
<b>Lamps flicker or strobe</b>	Lamp-ballast wiring error.	Ensure connections between ballast and lamps are exactly as shown on ballast label.
	Shunted sockets. SuperDim ballasts require non-shunted sockets, also known as rapid-start or program-start sockets.	Inspect or test lamp holders (sockets). With lamp removed and ballast disconnected, a shunted socket will always present a short circuit (zero ohms) between connections. Non-shunted sockets do not provide a connection (internal or external) between the blades.
	Poor starting aid. (not applicable to CFL models)	Ensure that a grounded metallic surface is within proper distance of the lamps. Spacing between the lamp wall and the grounded metallic surface should be between 0.125 and 0.500 in. for the entire length of the fluorescent tube. This requirement applies to linear fluorescents only.
	Incorrect lamps.	Ensure lamp selection matches ballast capabilities.
	Excessive lead lengths.	Lamp leads must not exceed their specified lengths and, when practical, excess length should be removed. Lamp leads should not be bunched, bundled or tightly dressed by wire ties or other means.
	Ballast not properly grounded.	Fixture must be properly grounded, and ballast housing must have good electrical contact with metallic fixture chassis. Use of a star washer or other paint penetrating device is recommended for ballast mounting. Some ballasts provide a ground terminal as an alternative means to make this connection.
	Cold lamps New lamps	Ensure ambient temperature meets or exceeds the ballast's minimum starting temperature and is also suitable for the selected lamps. Some lamp manufacturers recommend burning lamps at full intensity for at least 12 hours before dimming.
<b>Intermittent or unpredictable operation</b>	Loose connection.	Check power wiring, luminaire disconnect, circuit breaker, etc. Check control circuit for intermittent connections.
	Ballast not properly grounded.	Fixture must be properly grounded, and ballast housing must have good electrical contact with metallic fixture chassis. Use of a star washer or other paint penetrating device is recommended for ballast mounting. Some ballasts provide a ground terminal as an alternative means to make this connection.
	Shunted sockets. SuperDim ballasts require non-shunted sockets, also known as rapid-start or program-start sockets.	Inspect or test lamp holders (sockets). With lamp removed and ballast disconnected, a shunted socket will always present a short circuit (zero ohms) between connections. Non-shunted sockets do not provide a connection (internal or external) between the blades.
	Poor starting aid. (not applicable to CFL models)	Ensure that a grounded metallic surface is within proper distance of the lamps. Spacing between the lamp wall and the grounded metallic surface should be between 0.125 and 0.500 in. for the entire length of the fluorescent tube. This requirement applies to linear fluorescents only.
<b>Lamps ends turn black and/or frequent lamp failures</b>	Shunted sockets. SuperDim ballasts require non-shunted sockets, also known as rapid-start or program-start sockets.	Inspect or test lamp holders (sockets). With lamp removed and ballast disconnected, a shunted socket will always present a short circuit (zero ohms) between connections. Non-shunted sockets do not provide a connection (internal or external) between the blades.
	Lamp-ballast wiring error.	Ensure connections between ballast and lamps are exactly as shown on ballast label.
	Incorrect lamps.	Ensure lamp selection matches ballast capabilities.

## Additional Troubleshooting Techniques

In some cases, the troubleshooting methods outlined above may not lead to a quick detection and resolution of the problem. In this case, it is often beneficial to perform one or more of the following methods.

Method	Explanation
<b>System division</b>	When a large system of SuperDim ballasts has an apparent malfunction, but the specific component or location of the malfunctions is unknown, the system can be divided near the center of the control circuit. If the malfunction persists on one side, but not the other, the scope of the troubleshooting effort is reduced. Further separations may be used, of course, to help find the actual trouble site.
<b>Bypass installed control wires and do step-wise system reconstruction</b>	When the cause of a malfunction cannot be assigned to a ballast or to the control wires, ballasts can be individually tested using a known good controller connected by external control wires. The system can then be reconstructed in steps, using only a few ballasts and short sections of the installed control wiring at one time. If a problem is encountered during this process, the cause can often be attributed to the ballast or control wires added in the last step.



## IT'S EASY TO REACH US...



Universal Lighting Technologies, Inc.  
26 Century Blvd., Suite 500  
Nashville, TN 37214-3683



General Info: (615) 316-5100  
For Technical Engineering Services (TES),  
application support and warranty information,  
call 1-800-BALLAST



Website: [www.unvlt.com](http://www.unvlt.com)  
Email: [webmaster@unvlt.com](mailto:webmaster@unvlt.com)

All specification information is subject to change without notification.  
Lit# SDTBO211

[www.unvlt.com](http://www.unvlt.com)

Universal Lighting Technologies is a subsidiary of Panasonic  
Electric Works Co., Ltd., a member of the Panasonic Group

**Panasonic**

**Universal**  
Lighting Technologies