

Energy Management System

DCL[®] with DEMANDflex[®]

DEMANDflex[®] ballasts are high efficiency program start ballasts with the flexibility to be tuned at the circuit level to fixed power levels during installation. They are fully compatible with occupancy sensors and exceed the CEE requirements for high efficiency program start T8 ballasts. DEMANDflex[®] ballasts having tuning capabilities with ranges from 100% to 50% power levels, making them applicable for a wide range of lighting installations.

Installations can start with DEMANDflex[®] ballasts and after installation, the ballasts can be tuned to maximize energy savings with fixed light levels. No dimming control wires are associated with DEMANDflex[®] ballasts which makes them easy to install in all existing fluorescent lighting applications. DEMANDflex[®] ballasts can also be integrated with DCL[®] controls to be part of the most cost-effective lighting system available.

DCL[®] controls allow for local control with energy management systems and external control via the internet for networked managed systems. DCL[®] controls allow for integration with utility demand response programs that provide for improved pricing contracts to end-users in exchange for the utility to have the ability to lower lighting power levels during periods of high demand.



Product Overview

DEMANDflex® Ballasts

- Power level tuning potential to 50%
 - Set the circuit power level at installation
 - Typical 10% to 15% power reduction
- Install the same as standard PRS ballasts
 - No control wires necessary
 - Standard mounting footprint
 - Same wiring as program rapid start ballasts
- High efficiency program start operation
 - Exceeds CEE T8 requirements
 - Compatible with occupancy sensors
- NEMA premium
 - Exceeds CEE T8 requirements
 - Compatible with occupancy sensors

DCL® Controlled Systems

- Reduces lighting power by up to 50%
 - Avoid high peak charges
 - Reduce demand costs
- Programmable fade rates
 - Gradual transitions
 - No disruptions
- Use existing power connections to communicate to the ballasts
 - No control wires
- Implement with various controls and systems
 - BAS Systems
 - Photo Cells
 - Occupancy Sensors
 - Contact Closure

For more information contact Universal or visit www.unvlt.com.

- Universal DCL® Dimming
- Programmed Rapid Start
- 1, 2, 3, & 4 Lamp Applications
- Visit www.unvlt.com for a comprehensive description of the DCL® system and DEMANDflex® ballasts

Lamp		Line Volts	Catalog Number	CertificationLine		Input Current (Amps)	Power Power (Watts)	Ballast Factor (PF)	Ballast Factor (BF)	Efficacy Factor (BEF)	Min. F/C THD %	Start Temp	Wiring Diag.	Dim.		
Qty.	Starting Method			c	UL											
F32T8 - One Lamp Applications																
1	PRS	120	B232PUNVDR-A @ 100%	•	•	0.24	29	> .95	0.88	3.01	< 10	32/0	12a	-A		
			B232PUNVDR-A @ 50%	•	•	0.11	14	> .95	0.28	2.05	< 15	32/0	12a	-A		
		277	B232PUNVDR-A @ 100%	•	•	0.11	29	> .95	0.88	3.03	< 10	32/0	12a	-A		
			B232PUNVDR-A @ 50%	•	•	0.05	14	> .90	0.28	1.96	< 15	32/0	12a	-A		
		120	B232PUNVDRH-A @ 100%	•	•	0.32	38	> .95	1.15	3.03	< 10	32/0	12a	-A		
			B232PUNVDRH-A @ 50%	•	•	0.15	18	> .95	0.50	2.78	< 10	32/0	12a	-A		
		277	B232PUNVDRH-A @ 100%	•	•	0.14	39	> .95	1.15	2.95	< 10	32/0	12a	-A		
			B232PUNVDRH-A @ 50%	•	•	0.07	19	> .95	0.50	2.63	< 10	32/0	12a	-A		
		120	B232PUNVDRL-A @ 100%	•	•	0.20	24	> .95	0.68	2.85	< 10	32/0	12a	-A		
			B232PUNVDRL-A @ 50%	•	•	0.09	11	> .95	0.18	1.64	< 10	32/0	12a	-A		
		277	B232PUNVDRL-A @ 100%	•	•	0.09	24	> .95	0.68	2.85	< 10	32/0	12a	-A		
			B232PUNVDRL-A @ 50%	•	•	0.05	12	> .95	0.18	1.57	< 10	32/0	12a	-A		
		F32T8 - Two Lamp Applications														
		2	PRS	120	B232PUNVDR-A @ 100%	•	•	0.47	57	> .95	0.87	1.53	< 10	32/0	12b	-A
B232PUNVDR-A @ 50%	•				•	0.22	28	> .95	0.34	1.20	< 10	32/0	12b	-A		
277	B232PUNVDR-A @ 100%			•	•	0.20	56	> .95	0.87	1.56	< 10	32/0	12b	-A		
	B232PUNVDR-A @ 50%			•	•	0.10	28	> .95	0.35	1.22	< 10	32/0	12b	-A		
120	B232PUNVDRH-A @ 100%			•	•	0.62	75	> .95	1.15	1.53	< 10	32/0	12b	-A		
	B232PUNVDRH-A @ 50%			•	•	0.30	37	> .90	0.50	1.35	< 10	32/0	12b	-A		
277	B232PUNVDRH-A @ 100%			•	•	0.26	73	> .95	1.15	1.58	< 10	32/0	12b	-A		
	B232PUNVDRH-A @ 50%			•	•	0.13	36	> .90	0.50	1.39	< 10	32/0	12b	-A		
120	B232PUNVDRL-A @ 100%			•	•	0.40	47	> .95	0.71	1.51	< 10	32/0	12b	-A		
	B232PUNVDRL-A @ 50%			•	•	0.19	24	> .95	0.19	0.81	< 10	32/0	12b	-A		
277	B232PUNVDRL-A @ 100%			•	•	0.17	47	> .95	0.71	1.51	< 10	32/0	12b	-A		
	B232PUNVDRL-A @ 50%			•	•	0.09	24	> .95	0.19	0.81	< 10	32/0	12b	-A		
F32T8 - Three Lamp Applications																
3	PRS			120	B332PUNVDR-A @ 100%	•	•	0.70	85	> .95	0.87	1.02	< 10	32/0	12c	-A
		B332PUNVDR-A @ 50%	•		•	0.34	42	> .95	0.35	0.83	< 10	32/0	12c	-A		
		277	B332PUNVDR-A @ 100%	•	•	0.30	83	> .95	0.87	1.05	< 10	32/0	12c	-A		
			B332PUNVDR-A @ 50%	•	•	0.16	41	> .95	0.35	0.85	< 10	32/0	12c	-A		
		120	B332PUNVDRL-A @ 100%	•	•	0.59	72	> .95	0.71	0.99	< 10	32/0	12c	-A		
			B332PUNVDRL-A @ 50%	•	•	0.29	36	> .95	0.22	0.61	< 10	32/0	12c	-A		
		277	B332PUNVDRL-A @ 100%	•	•	0.25	72	> .95	0.71	0.99	< 10	32/0	12c	-A		
			B332PUNVDRL-A @ 50%	•	•	0.13	36	> .95	0.22	0.61	< 10	32/0	12c	-A		
		120	B332PUNVDRH-E @ 100%	•	•	0.95	115	> .95	1.15	1.00	< 10	32/0	12d	-E		
			B332PUNVDRH-E @ 50%	•	•	0.48	57	> .95	0.50	0.88	< 10	32/0	12d	-E		
		277	B332PUNVDRH-E @ 100%	•	•	0.41	111	> .95	1.15	1.04	< 10	32/0	12d	-E		
			B332PUNVDRH-E @ 50%	•	•	0.21	55	> .95	0.50	0.91	< 10	32/0	12d	-E		
		F32T8 - Four Lamp Applications														
		4	PRS	120	B432PUNVDR-E @ 100%	•	•	0.96	116	> .95	0.88	0.75	< 10	32/0	12e	-E
B432PUNVDR-E @ 50%	•				•	0.48	58	> .95	0.35	0.60	< 10	32/0	12e	-E		
277	B432PUNVDR-E @ 100%			•	•	0.41	112	> .95	0.88	0.79	< 10	32/0	12e	-E		
	B432PUNVDR-E @ 50%			•	•	0.20	56	> .95	0.35	0.63	< 15	32/0	12e	-E		
120	B432PUNVDRL-E @ 100%			•	•	0.78	93	> .95	0.71	0.76	< 10	32/0	12e	-E		
	B432PUNVDRL-E @ 50%			•	•	0.37	47	> .95	0.21	0.45	< 15	32/0	12e	-E		
277	B432PUNVDRL-E @ 100%			•	•	0.34	93	> .95	0.71	0.76	< 10	32/0	12e	-E		
	B432PUNVDRL-E @ 50%			•	•	0.17	47	> .95	0.21	0.45	< 15	32/0	12e	-E		

See page 3-7 for Dimensions and Wiring Diagrams

- Universal DCL[®] Dimming
- Programmed Rapid Start
- 1, 2, 3, & 4 Lamp Applications
- Visit www.unvlt.com for a comprehensive description of the DCL system and DEMANDflex ballasts

Lamp Qty.	Starting Method	Line Volts	Catalog Number	Certification		Input Current (Amps)	Power Power (Watts)	Ballast Factor (PF)	Ballast Factor (BF)	Efficacy Factor (BEF)	Min. F/C THD %	Start Temp	Wiring Diag.	Dim.
				c	UL									
F25T8 - One Lamp Applications														
1	PRS	120	B232PUNVDR-A @ 100%	•	•	0.19	22	> .95	0.87	4.00	< 10	32/0	12a	-A
			B232PUNVDR-A @ 50%	•	•	0.10	12	> .95	0.35	2.93	< 15	32/0	12a	-A
		277	B232PUNVDR-A @ 100%	•	•	0.08	22	> .95	0.88	3.95	< 10	32/0	12a	-A
			B232PUNVDR-A @ 50%	•	•	0.05	13	> .90	0.35	2.82	< 10	32/0	12a	-A
		120	B232PUNVDRH-A @ 100%	•	•	0.25	30	> .95	1.16	3.87	< 10	32/0	12a	-A
			B232PUNVDRH-A @ 50%	•	•	0.12	14	> .95	0.50	3.57	< 10	32/0	12a	-A
		277	B232PUNVDRH-A @ 100%	•	•	0.11	30	> .95	1.16	3.81	< 10	32/0	12a	-A
			B232PUNVDRH-A @ 50%	•	•	0.06	15	> .90	0.50	3.33	< 10	32/0	12a	-A
		120	B232PUNVDRL-A @ 100%	•	•	0.15	18	> .95	0.69	3.85	< 10	32/0	12a	-A
			B232PUNVDRL-A @ 50%	•	•	0.08	10	> .95	0.18	1.84	< 15	32/0	12a	-A
		277	B232PUNVDRL-A @ 100%	•	•	0.07	18	> .95	0.69	3.77	< 10	32/0	12a	-A
			B232PUNVDRL-A @ 50%	•	•	0.04	10	> .95	0.18	1.75	< 15	32/0	12a	-A
F25T8 - Two Lamp Applications														
2	PRS	120	B232PUNVDR-A @ 100%	•	•	0.36	44	> .95	0.87	2.01	< 10	32/0	12b	-A
			B232PUNVDR-A @ 50%	•	•	0.19	23	> .95	0.35	1.56	< 10	32/0	12b	-A
		277	B232PUNVDR-A @ 100%	•	•	0.16	43	> .95	0.87	2.05	< 10	32/0	12b	-A
			B232PUNVDR-A @ 50%	•	•	0.09	23	> .95	0.35	1.53	< 10	32/0	12b	-A
		120	B232PUNVDRH-A @ 100%	•	•	0.46	55	> .95	1.15	2.09	< 10	32/0	12b	-A
			B232PUNVDRH-A @ 50%	•	•	0.21	26	> .90	0.50	1.92	< 10	32/0	12b	-A
		277	B232PUNVDRH-A @ 100%	•	•	0.20	55	> .95	1.15	2.08	< 10	32/0	12b	-A
			B232PUNVDRH-A @ 50%	•	•	0.10	26	> .90	0.50	1.92	< 10	32/0	12b	-A
		120	B232PUNVDRL-A @ 100%	•	•	0.30	36	> .95	0.69	1.93	< 10	32/0	12b	-A
			B232PUNVDRL-A @ 50%	•	•	0.15	18	> .95	0.19	1.06	< 10	32/0	12b	-A
		277	B232PUNVDRL-A @ 100%	•	•	0.13	35	> .95	0.69	1.95	< 10	32/0	12b	-A
			B232PUNVDRL-A @ 50%	•	•	0.07	18	> .95	0.19	1.03	< 10	32/0	12b	-A
F25T8 - Three Lamp Applications														
3	PRS	120	B332PUNVDR-A @ 100%	•	•	0.55	66	> .95	0.87	1.32	< 10	32/0	12c	-A
			B332PUNVDR-A @ 50%	•	•	0.27	33	> .95	0.35	1.06	< 10	32/0	12c	-A
		277	B332PUNVDR-A @ 100%	•	•	0.24	65	> .95	0.87	1.34	< 10	32/0	12c	-A
			B332PUNVDR-A @ 50%	•	•	0.13	32	> .95	0.35	1.09	< 15	32/0	12c	-A
		120	B332PUNVDRL-A @ 100%	•	•	0.47	56	> .95	0.71	1.27	< 10	32/0	12c	-A
			B332PUNVDRL-A @ 50%	•	•	0.24	28	> .95	0.23	0.81	< 10	32/0	12c	-A
		277	B332PUNVDRL-A @ 100%	•	•	0.21	55	> .95	0.71	1.29	< 10	32/0	12c	-A
			B332PUNVDRL-A @ 50%	•	•	0.11	29	> .90	0.23	0.80	< 10	32/0	12c	-A
		120	B332PUNVDRH-E @ 100%	•	•	0.74	89	> .95	1.17	1.31	< 10	32/0	12d	-E
			B332PUNVDRH-E @ 50%	•	•	0.35	42	> .95	0.50	1.19	< 15	32/0	12d	-E
		277	B332PUNVDRH-E @ 100%	•	•	0.33	89	> .95	1.17	1.31	< 10	32/0	12d	-E
			B332PUNVDRH-E @ 50%	•	•	0.16	43	> .95	0.50	1.16	< 15	32/0	12d	-E
F25T8 - Four Lamp Applications														
4	PRS	120	B432PUNVDR-E @ 100%	•	•	0.75	90	> .95	0.89	0.99	< 10	32/0	12e	-E
			B432PUNVDR-E @ 50%	•	•	0.37	44	> .95	0.35	0.80	< 15	32/0	12e	-E
		277	B432PUNVDR-E @ 100%	•	•	0.33	89	> .95	0.89	1.00	< 10	32/0	12e	-E
			B432PUNVDR-E @ 50%	•	•	0.17	44	> .90	0.35	0.80	< 15	32/0	12e	-E
		120	B432PUNVDRL-E @ 100%	•	•	0.61	73	> .95	0.71	0.97	< 10	32/0	12e	-E
			B432PUNVDRL-E @ 50%	•	•	0.31	37	> .95	0.21	0.56	< 15	32/0	12e	-E
		277	B432PUNVDRL-E @ 100%	•	•	0.27	72	> .95	0.71	0.98	< 10	32/0	12e	-E
			B432PUNVDRL-E @ 50%	•	•	0.15	38	> .90	0.21	0.56	< 15	32/0	12e	-E

See page 3-7 for Dimensions and Wiring Diagrams

DEMANDflex®

FOR (1), (2), (3) & (4) LAMPS

- Universal DCL® Dimming
- Programmed Rapid Start
- 1, 2, 3, & 4 Lamp Applications
- Visit www.unvlt.com for a comprehensive description of the DCL system and DEMANDflex ballasts

DEMANDflex
T8

Lamp Qty.	Starting Method	Line Volts	Catalog Number	CertificationLine		Input Current (Amps)	Power Power (Watts)	Ballast Factor (PF)	Ballast Factor (BF)	Efficacy Factor (BEF)	Min. F/C THD %	Start Temp	Wiring Diag.	Dim.
				c	UL									
F17T8 - One Lamp Applications														
1	PRS	120	B232PUNVDR-A @ 100%	•	•	0.14	16	> .95	0.92	5.65	< 10	32/0	12a	-A
			B232PUNVDR-A @ 50%	•	•	0.08	10	> .95	0.27	2.81	< 15	32/0	12a	-A
		277	B232PUNVDR-A @ 100%	•	•	0.06	17	> .95	0.92	5.48	< 10	32/0	12a	-A
			B232PUNVDR-A @ 50%	•	•	0.04	10	> .85	0.27	2.66	< 15	32/0	12a	-A
		120	B232PUNVDRH-A @ 100%	•	•	0.18	22	> .95	1.15	5.23	< 10	32/0	12a	-A
			B232PUNVDRH-A @ 50%	•	•	0.09	11	> .95	0.50	4.63	< 15	32/0	12a	-A
		277	B232PUNVDRH-A @ 100%	•	•	0.09	22	> .95	1.15	5.23	< 10	32/0	12a	-A
			B232PUNVDRH-A @ 50%	•	•	0.05	11	> .90	0.50	4.55	< 15	32/0	12a	-A
		120	B232PUNVDRL-A @ 100%	•	•	0.11	13	> .95	0.70	5.47	< 10	32/0	12a	-A
			B232PUNVDRL-A @ 50%	•	•	0.09	10	> .95	0.20	1.98	< 15	32/0	12a	-A
		277	B232PUNVDRL-A @ 100%	•	•	0.05	13	> .95	0.70	5.22	< 10	32/0	12a	-A
			B232PUNVDRL-A @ 50%	•	•	0.04	11	> .85	0.20	1.87	< 15	32/0	12a	-A
F17T8 - Two Lamp Applications														
2	PRS	120	B232PUNVDR-A @ 100%	•	•	0.25	30	> .95	0.90	3.00	< 10	32/0	12b	-A
			B232PUNVDR-A @ 50%	•	•	0.13	16	> .95	0.27	1.72	< 10	32/0	12b	-A
		277	B232PUNVDR-A @ 100%	•	•	0.13	30	> .95	0.90	3.00	< 10	32/0	12b	-A
			B232PUNVDR-A @ 50%	•	•	0.06	16	> .95	0.27	1.67	< 10	32/0	12b	-A
		120	B232PUNVDRH-A @ 100%	•	•	0.32	38	> .95	1.16	3.05	< 10	32/0	12b	-A
			B232PUNVDRH-A @ 50%	•	•	0.16	19	> .95	0.50	2.63	< 10	32/0	12b	-A
		277	B232PUNVDRH-A @ 100%	•	•	0.14	39	> .95	1.16	2.97	< 10	32/0	12b	-A
			B232PUNVDRH-A @ 50%	•	•	0.07	19	> .90	0.50	2.63	< 10	32/0	12b	-A
		120	B232PUNVDRL-A @ 100%	•	•	0.21	25	> .95	0.69	2.78	< 10	32/0	12b	-A
			B232PUNVDRL-A @ 50%	•	•	0.12	15	> .95	0.19	1.29	< 15	32/0	12b	-A
		277	B232PUNVDRL-A @ 100%	•	•	0.09	25	> .95	0.69	2.76	< 10	32/0	12b	-A
			B232PUNVDRL-A @ 50%	•	•	0.06	15	> .95	0.19	1.24	< 10	32/0	12b	-A
F17T8 - Three Lamp Applications														
3	PRS	120	B332PUNVDR-A @ 100%	•	•	0.40	48	> .95	0.89	1.86	< 10	32/0	12c	-A
			B332PUNVDR-A @ 50%	•	•	0.20	24	> .95	0.36	1.51	< 10	32/0	12c	-A
		277	B332PUNVDR-A @ 100%	•	•	0.18	48	> .95	0.89	1.86	< 10	32/0	12c	-A
			B332PUNVDR-A @ 50%	•	•	0.10	24	> .90	0.36	1.51	< 15	32/0	12c	-A
		120	B332PUNVDRL-A @ 100%	•	•	0.33	40	> .95	0.73	1.83	< 10	32/0	12c	-A
			B332PUNVDRL-A @ 50%	•	•	0.18	22	> .95	0.23	1.05	< 10	32/0	12c	-A
		277	B332PUNVDRL-A @ 100%	•	•	0.15	40	> .95	0.73	1.83	< 10	32/0	12c	-A
			B332PUNVDRL-A @ 50%	•	•	0.09	23	> .85	0.23	1.02	< 15	32/0	12c	-A
		120	B332PUNVDRH-E @ 100%	•	•	0.54	65	> .95	1.19	1.83	< 10	32/0	12d	-E
			B332PUNVDRH-E @ 50%	•	•	0.25	32	> .95	0.51	1.59	< 15	32/0	12d	-E
		277	B332PUNVDRH-E @ 100%	•	•	0.24	65	> .95	1.19	1.84	< 10	32/0	12d	-E
			B332PUNVDRH-E @ 50%	•	•	0.12	32	> .90	0.51	1.59	< 15	32/0	12d	-E
F17T8 - Four Lamp Applications														
4	PRS	120	B432PUNVDR-E @ 100%	•	•	0.53	64	> .95	0.91	1.42	< 10	32/0	12e	-E
			B432PUNVDR-E @ 50%	•	•	0.27	32	> .95	0.35	1.09	< 15	32/0	12e	-E
		277	B432PUNVDR-E @ 100%	•	•	0.24	63	> .95	0.91	1.44	< 10	32/0	12e	-E
			B432PUNVDR-E @ 50%	•	•	0.13	32	> .90	0.35	1.09	< 15	32/0	12e	-E
		120	B432PUNVDRL-E @ 100%	•	•	0.43	52	> .95	0.73	1.41	< 10	32/0	12e	-E
			B432PUNVDRL-E @ 50%	•	•	0.26	31	> .95	0.21	0.69	< 15	32/0	12e	-E
		277	B432PUNVDRL-E @ 100%	•	•	0.20	52	> .95	0.73	1.41	< 10	32/0	12e	-E
			B432PUNVDRL-E @ 50%	•	•	0.12	31	> .90	0.21	0.67	< 15	32/0	12e	-E

See page 3-7 for Dimensions and Wiring Diagrams

- Universal DCL® Dimming
- Programmed Rapid Start
- 2 Lamp Applications for T5HO
- 1 & 2 Lamp Applications for T5
- Visit www.unvlt.com for a comprehensive description of the DCL system and DEMANDflex ballasts

Lamp Qty.	Starting Method	Line Volts	Catalog Number	Certification		Line Current (Amps)	Input Power (Watts)	Power Factor (PF)	Ballast Factor (BF)	Ballast Efficacy Factor (BEF)	THD %	Min. F/C Start Temp	Wiring Diag.	Dim.
				c	UL									
F28T5 - One Lamp Applications														
1	PRS	120	B128PUNVDRH-D @ 100%	•	•	0.32	37	> .99	1.15	3.11	< 10	50/10	12g	-D
			B128PUNVDRH-D @ 50%	•	•	0.16	19	> .99	0.38	2.00	< 10	50/10	12g	-D
		277	B128PUNVDRH-D @ 100%	•	•	0.14	37	> .96	1.15	3.11	< 10	50/10	12g	-D
			B128PUNVDRH-D @ 50%	•	•	0.08	19	> .88	0.38	2.00	< 10	50/10	12g	-D
F28T5 - Two Lamp Applications														
2	PRS	120	B228PUNVDRH-D @ 100%	•	•	0.60	72	> .95	1.15	1.60	< 10	50/10	12f	-D
			B228PUNVDRH-D @ 50%	•	•	0.30	36	> .95	0.51	1.42	< 10	50/10	12f	-D
		277	B228PUNVDRH-D @ 100%	•	•	0.25	70	> .95	1.15	1.64	< 10	50/10	12f	-D
			B228PUNVDRH-D @ 50%	•	•	0.13	35	> .95	0.50	1.43	< 10	50/10	12f	-D
F35T5 - Two Lamp Applications														
2	PRS	120	B228PUNVDRH-D @ 100%	•	•	0.75	90	> .95	1.13	1.26	< 10	50/10	12f	-D
			B228PUNVDRH-D @ 50%	•	•	0.38	45	> .95	0.51	1.13	< 10	50/10	12f	-D
		277	B228PUNVDRH-D @ 100%	•	•	0.31	87	> .95	1.13	1.30	< 10	50/10	12f	-D
			B228PUNVDRH-D @ 50%	•	•	0.17	44	> .95	0.51	1.16	< 10	50/10	12f	-D
F21T5 - One Lamp Applications														
1	PRS	120	B128PUNVDRH-D @ 100%	•	•	0.25	28	> .99	1.15	4.11	< 10	50/10	12g	-D
			B128PUNVDRH-D @ 50%	•	•	0.13	15	> .99	0.38	2.53	< 10	50/10	12g	-D
		277	B128PUNVDRH-D @ 100%	•	•	0.12	28	> .94	1.15	4.11	< 10	50/10	12g	-D
			B128PUNVDRH-D @ 50%	•	•	0.07	15	> .84	0.38	2.53	< 10	50/10	12g	-D
F21T5 - Two Lamp Applications														
2	PRS	120	B228PUNVDRH-D @ 100%	•	•	0.47	56	> .95	1.16	2.07	< 10	50/10	12f	-D
			B228PUNVDRH-D @ 50%	•	•	0.23	28	> .95	0.51	1.82	< 10	50/10	12f	-D
		277	B228PUNVDRH-D @ 100%	•	•	0.20	55	> .95	1.16	2.11	< 10	50/10	12f	-D
			B228PUNVDRH-D @ 50%	•	•	0.11	28	> .90	0.51	1.82	< 10	50/10	12f	-D
F14T5 - Two Lamp Applications														
2	PRS	120	B228PUNVDRH-D @ 100%	•	•	0.34	40	> .95	1.17	2.93	< 10	50/10	12f	-D
			B228PUNVDRH-D @ 50%	•	•	0.16	19	> .95	0.52	2.74	< 10	50/10	12f	-D
		277	B228PUNVDRH-D @ 100%	•	•	0.15	40	> .95	1.17	2.93	< 10	50/10	12f	-D
			B228PUNVDRH-D @ 50%	•	•	0.08	20	> .85	0.52	2.60	< 10	50/10	12f	-D
F54T5HO - Two Lamp Applications														
2	PRS	120	B254PUNVDR-D @ 100%	•	•	1.00	120	> .95	1.00	0.83	< 10	0/-18	12f	-D
			B254PUNVDR-D @ 50%	•	•	0.50	60	> .95	0.45	0.75	< 10	0/-18	12f	-D
		277	B254PUNVDR-D @ 100%	•	•	0.43	120	> .95	1.00	0.83	< 10	0/-18	12f	-D
			B254PUNVDR-D @ 50%	•	•	0.22	60	> .90	0.45	0.75	< 10	0/-18	12f	-D
FT55W/2G11 - Two Lamp Applications														
2	PRS	120	B254PUNVDR-D @ 100%	•	•	0.90	108	> .95	1.06	0.98	< 10	0/-18	12f	-D
			B254PUNVDR-D @ 50%	•	•	0.41	50	> .95	0.57	1.14	< 10	0/-18	12f	-D
		277	B254PUNVDR-D @ 100%	•	•	0.39	106	> .95	1.06	1.00	< 10	0/-18	12f	-D
			B254PUNVDR-D @ 50%	•	•	0.19	50	> .95	0.57	1.14	< 10	0/-18	12f	-D
FT50W/2G11 - Two Lamp Applications														
2	PRS	120	B254PUNVDR-D @ 100%	•	•	0.97	115	> .95	1.10	0.96	< 10	0/-18	12f	-D
			B254PUNVDR-D @ 50%	•	•	0.47	57	> .95	0.63	1.11	< 10	0/-18	12f	-D
		277	B254PUNVDR-D @ 100%	•	•	0.42	113	> .95	1.11	0.98	< 10	0/-18	12f	-D
			B254PUNVDR-D @ 50%	•	•	0.21	57	> .95	0.63	1.11	< 10	0/-18	12f	-D
FC55T5-55W - Two Lamp Applications														
2	PRS	120	B254PUNVDR-D @ 100%	•	•	0.88	106	> .95	1.04	0.98	< 10	0/-18	12f	-D
			B254PUNVDR-D @ 50%	•	•	0.41	49	> .95	0.56	1.14	< 10	0/-18	12f	-D
		277	B254PUNVDR-D @ 100%	•	•	0.38	104	> .95	1.04	1.00	< 10	0/-18	12f	-D
			B254PUNVDR-D @ 50%	•	•	0.19	48	> .95	0.56	1.17	< 10	0/-18	12f	-D
F21T5-55W - One Lamp Application														
2	PRS	120	B254PUNVDR-D @ 100%	•	•	0.88	106	> .95	1.04	0.98	< 10	0/-18	12f	-D
			B254PUNVDR-D @ 50%	•	•	0.41	49	> .95	0.56	1.14	< 10	0/-18	12f	-D

See page 3-7 for Dimensions and Wiring Diagrams

WIRING DIAGRAMS

Note: Nominal dimensions provided above
Contact Universal for drawings and/or tolerances

Ballast case must be grounded. A star washer or other paint penetrating device is required.

Wiring Diagram 12a



Wiring Diagram 12e

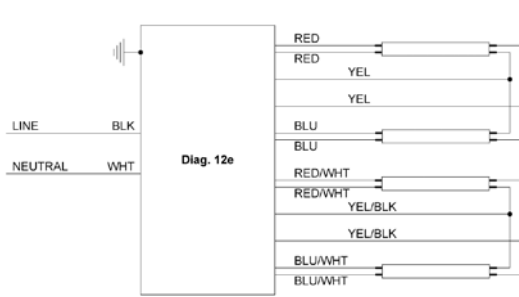

Wiring Diagram 12b

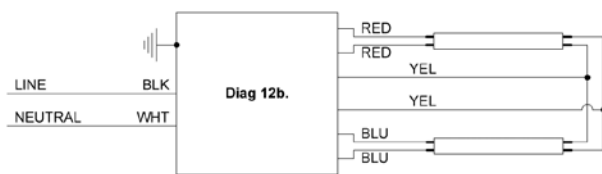

Wiring Diagram 12f

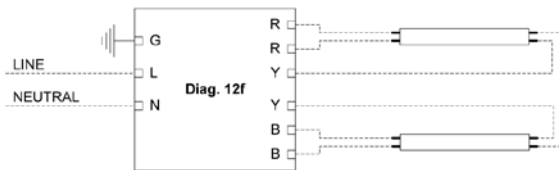

Wiring Diagram 12c



Wiring Diagram 12g

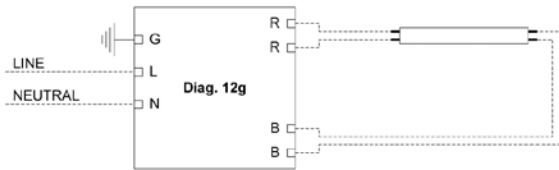

Wiring Diagram 12d

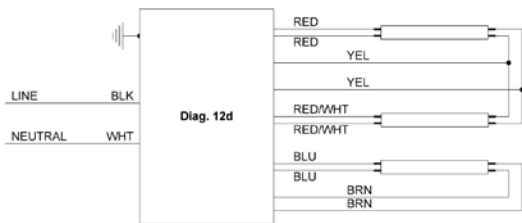

Overall Dimensions			Mounting Dimensions		
Draw #	L	W	H	M	X
-A	9.50"	1.70"	1.18"	8.89"	1.69"
-D	16.88"	1.18"	1.00"	16.20"	—
-E	16.88"	1.82"	1.18"	16.28"	—

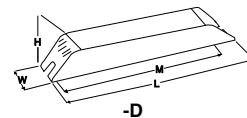
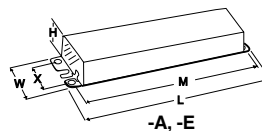

DCL CONTROLS

MODEL	DESCRIPTION
LP12DCLUNV-xx**	Circuit Control Panel
SC20DCLUNV**	Single Circuit Controller
MC20DCLUNV**	Open Style Single Circuit Controller
RSDMCL51	Contact Interface Controller
WTPDCL51 ^Δ	Time/Photo Controller
WPS5527K	Photo Sensor for WTPDCL

xx = number of circuits (03 - 12)

* For additional lighting system controllers, contact Universal Lighting.

** Modbus versions of these controls are available.

^Δ Consult Universal for configuration options.

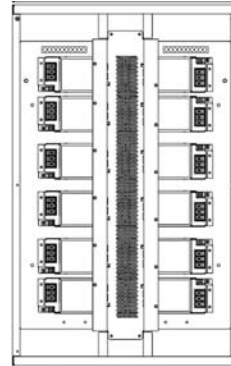

LP12DCLUNV-xx		
Dimensions	Mounting	
Length	32"	24"
Width	20"	16"
Depth	4.3"	

The same cabinet size is used for the four different panels. The quantity of individual controllers installed is determined by the model number.

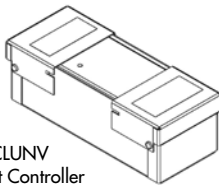

SC20DCLUNV
Single Circuit Controller

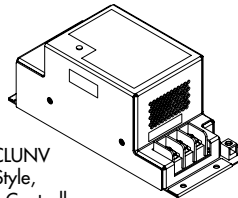

MC20DCLUNV
Open Style,
Single Circuit Controller

SC20DCLUNV	MOUNTING PATTERN
Dimensions	
Length	9.66"
Width	3.98"
Depth	3.21"

Circuit control panels are used to send commands down the lighting circuit to the DemandFlex ballasts. The LP12DCLUNV-xx panels are available with 3 to 12 integral circuit control modules. If more than 12 circuits are being controlled, additional panels can be used.

The SC20DCLUNV is used when there are a small number of circuits or space limitations prevent the use of an LP12DCLUNV panel.

One RSDMCL51 or WTPDCL51 can control up to 63 circuits. If more than 63 circuits are to be controlled, an RSDMCL can be connected in parallel with either controller for another 63 circuits.

Stand Alone Time Clock/Photo Cell Control

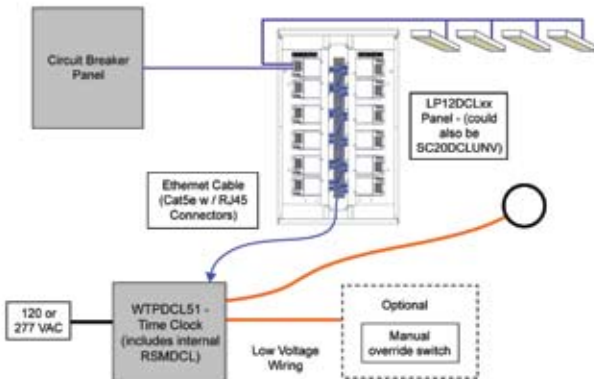

The WTPDCL51 controller provides time of day scheduling and can also be connected to the WPS5527K Photo Cell for daylight harvesting. Manual override switches are also available.

Note: Nominal dimensions provided above
Contact Universal for drawings and/or tolerances

Contact Closure Interface Control

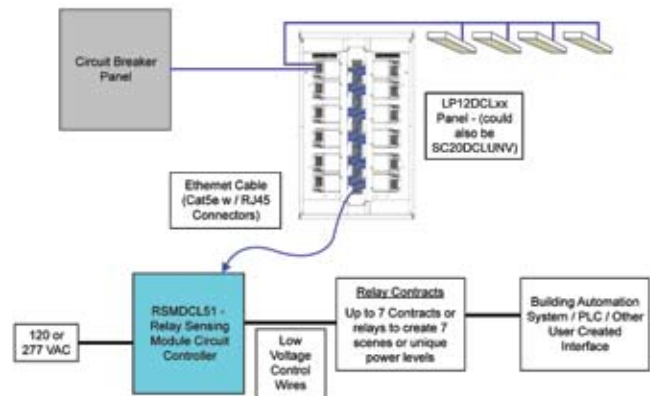

The RSDMCL51 controller integrates with external relays or switches to translate commands to the DCL system. This controller can be used to interface with building automation systems, PLC's, or switches. These systems may also incorporate photo cells for daylight harvesting.