

eHID

Less energy. Enhanced performances.

Experience significant energy savings and increased lumen output vs. halogen lamps with Electronic High Intensity Discharge (HID) ballasts from Universal Lighting Technologies. Vossloh-Schwabe (VS), also a Panasonic Lighting Company, recently merged its US operation into Universal. This merger combines Vossloh's market leading high quality electronic HID product line with Universal's extensive offering.

There are numerous advantages of using VS electronic HID ballasts. Operating HID lamps used in HID lighting systems with electronic ballasts greatly increases system efficiency in comparison with magnetic ballasts. These ballasts are designed to provide optimal lamp performance and maximum energy savings. With enhanced capabilities to downsize the form factor of luminaire housings and reduce wiring costs, VS electronic HID ballasts lead the way to electronic solutions for HID lighting. Micro-processor controlled intelligence offers superior lamp performance and the flexibility for proprietary value-added functions. VS electronic HID ballasts cover your HID needs with products for Metal Halide Lamps ranging from 20 Watts to 210 Watts.



VS electronic HID ballasts continuously monitors lamp characteristics during operation and adjusts the lamp current to optimize performance. This guarantees controlled operation in all modes of operation. The lamp color temperature is also stabilized by using VS electronic HID ballasts due to its relatively constant output power characteristics in addition to producing flicker free lighting that usually occurs at the end of the discharge lamp's service life. The technology enhancements of VS electronic HID ballasts, allowing very small form factors and light weight designs, has enabled new, innovative luminaire designs.

Product Overview

Micro Series: The introduction of the smallest eHID ballasts in the market was coordinated with the launch of the new miniaturized capsule MH lamps enabling the ultimate luminaire design flexibility. Extremely compact and aesthetically pleasing, luminaire designs are approaching the form factor and size of low voltage halogen systems.



Mini Ballast Series: Two ideal form factors that are used in millions of HID track light luminaires characterize the mini series of eHID ballasts. The mini-slim and mini-square units revolutionized track lighting by allowing significantly smaller and greater variety of luminaire designs while providing energy savings of 60-70% versus halogen systems.



Standard Case “Valued-added Series”: Millions of recessed, track-head and specialty luminaires have used the de facto industry standard enclosure since introduction. The significant energy savings and enhanced reliability of our ballasts promoted the rapid escalation of electronically ballasted MH luminaires for almost 15 years. Technological advancements have now allowed the integration of multiple, value-added functions such as: a powersource for the self-heating thermal protectors, an electronic 277V step-down transformer, and an intelligent auxiliary lighting control for back-up lighting during lamp hot restrike modes. Ideal for new, retrofit and replacement applications in recessed luminaires.

Features and Benefits:

- Optimum lamp performance
- Rugged, compact and lightweight design
- High power factor
- Enhanced color and CRI uniformity
- Shut-down protection
- Reduced wiring costs
- Eliminates nuisance lamp cycling at end-of-lamp life (intelligent lamp sensing capabilities)
- Constant lamp power
- Reduced lamp dropouts due to improved line voltage dip withstand
- Quiet operation
- Durable performance for various applications
- Fewer SKUs required in inventory
- Broadens design flexibility for new applications and luminaries

eHID Product Family

Part #	Description	Lamp Wattage	Lamp Type	Input Voltage	Input Power	Mounting	Lead Exit	Dimensions	Wiring
Micro Series									
188514	M2012CK-7EUN	20	M/C156	120	24.5	No Feet	Side	1	1
188882	M2012CK-7EUN-F	20	M/C156	120	24.5	Feet	Side	2	1
188883	M2012CK-7EUN-J	20	M/C156	120	24.5	Studs	Top	3	1
188574	M2212CK-7EUN	22	M/C175	120	26.5	No Feet	Side	1	1
188884	M2212CK-7EUN-F	22	M/C175	120	26.5	Feet	Side	2	1
188885	M2212CK-7EUN-J	22	M/C175	120	26.5	Studs	Top	3	1
188635	M3912CK-7EUN	39	M/C130	120	45	No Feet	Side	4	1
188776	M3912CK-7EUN-F	39	M/C130	120	45	Feet	Side	2	1
188756	M3912CK-7EUN-J	39	M/C130	120	45	Studs	Top	3	1
188757	MTm3912CK-7EUN	39Tm	M/C179	120	45	No Feet	Side	4	1
188777	MTm3912CK-7EUN-F	39Tm	M/C179	120	45	Feet	Side	2	1
188758	MTm3912CK-7EUN-J	39Tm	M/C179	120	45	Studs	Top	3	1
Mini-Slim Series									
188246	M3912CK-6EUN-F	39	M/C130	120	45	Feet	Side	5	1
188702	M3927CK-6EUN-F	39	M/C130	277	44	Feet	Side	6	1
188774	M3927CK-6EUN-J	39	M/C130	277	44	Studs	Top	7	1
188164	M7012CK-6EUN-F	70	M/C98, M/C139, M/C143	120	77	Feet	Side	5	1
188703	M7027CK-6EUN-F	70	M/C98, M/C139, M/C143	277	77	Feet	Side	6	1
188775	M7027CK-6EUN-J	70	M/C98, M/C139, M/C143	277	77	Studs	Top	7	1
Mini-Square Series									
188151	M2012CK-6EU-F	20	M/C156	120	23	Feet	Side	8	1
188627	M2012CK-6EU-J	20	M/C156	120	23	Studs	Top	9	1
188701	M2212CK-6EU-J	22	M/C175	120	26.5	Studs	Top	9	1
188293	M3912CK-6EU-F	39	M/C130	120	45	Feet	Side	8	1
188512	M3912CK-6EU-J	39	M/C130	120	45	Studs	Top	9	1
188402	M3927CK-6EU-F	39	M/C130	277	44	Feet	Side	10	1
188551	M3927CK-6EU-J	39	M/C130	277	44	Studs	Top	9	1
188377	JM7012CK-6EU-F	70	M/C98, M/C139, M/C143	120	77	Feet	Side	11	1
188628	M7012CK-6EU-J	70	M/C98, M/C139, M/C143	120	77	Studs	Top	9	1
188895	M3912-27CK-6EU-F	39	M/C130	120-277	44	Feet	Side	10	1
188896	M3912-27CK-6EU-J	39	M/C130	120-277	44	Studs	Top	9	1
188897	M3912/27CK-6EU-JT3	39	M/C130	120/277	44/46	Studs	Top	9	2a,2b,2c
188901	M2012-27CK-6EU-F	20	M/C156	120-277	24	Feet	Side	10	1
188902	M2012-27CK-6EU-J	20	M/C156	120-277	24	Studs	Top	9	1
188903	M2012/27CK-6EU-JT3	20	M/C156	120/277	24/26	Studs	Top	9	2a,2b,2c
188939	M7012-27CK-6EU-F	70	M/C98, M/C139, M/C143	120-277	77	Feet	Side	10	1
188940	M7012-27CK-6EU-J	70	M/C98, M/C139, M/C143	120-277	77	Studs	Top	9	1
188941	M7012/27CK-6EU-JT3	70	M/C98, M/C139, M/C143	120/277	77/79	Studs	Top	9	2a,2b,2c
Standard Series									
188610	M2012-27CK-5EU-F	20	M/C156	120-277	24	Feet	Side	12	1
188611	M2012/27CK-5EU-JT3	20	M/C156	120/277	24/26	Studs	Top	13	2a, 2b, 2c
188156	M3912-27CK-5EU	39	M/C130	120-277	44	No Feet	Side	14	1
188157	M3912-27CK-5EU-F	39	M/C130	120-277	44	Feet	Side	12	1
188301	M3912-27CK-5EU-J	39	M/C130	120-277	44	Studs	Top	13	1
188629	M3912/27CK-5EU-JT3	39	M/C130	120/277	44/46	Studs	Top	13	2a, 2b, 2c
188630	M3912/27CK-5EU-JA3	39	M/C130	120/277	46/187	Studs	Top	13	3a, 3b, 3c
188612	M5012-27CK-5EU-F	50	M148 or M110	120-277	56	Feet	Side	12	1
188613	M5012/27CK-5EU-JT3	50	M148 or M110	120/277	56/58	Studs	Top	13	2a, 2b, 2c
188165	M7012-27CK-5EU	70	M/C98, M/C139, M/C143	120-277	78	No Feet	Side	14	1
188166	M7012-27CK-5EU-F	70	M/C98, M/C139, M/C143	120-277	78	Feet	Side	12	1
188167	M7012-27CK-5EU-J	70	M/C98, M/C139, M/C143	120-277	78	Studs	Top	13	1
188631	M7012/27CK-5EU-JT3	70	M/C98, M/C139, M/C143	120/277	79/81	Studs	Top	13	2a, 2b, 2c
188632	M7012/27CK-5EU-JA3	70	M/C98, M/C139, M/C143	120/277	81/212	Studs	Top	13	3a, 3b, 3c
188633	M10012/27CK-5EU-JT3	100	M/C90, M/C140 and M/C164	120/277	110/212	Studs	Top	13	2a, 2b, 2c
188168	M10012-27CK-5EU	100	M/C90, M/C140 and M/C164	120-277	110	No Feet	Side	14	1
188169	M10012-27CK-5EU-F	100	M/C90, M/C140 and M/C164	120-277	110	Feet	Side	12	1
188302	M10012-27CK-5EU-J	100	M/C90, M/C140 and M/C164	120-277	110	Studs	Top	13	1
188634	M10012/27CK-5EU-JA3	100	M/C90, M/C140 and M/C164	120/277	112/235	Studs	Top	13	3a, 3b, 3c
188638*	M15012-27CK-5EU-F	150	M/C102/E and M/C142/E	120-277	163	Feet	Side	12	1
188639*	M15012-27CK-5EU-J	150	M/C102/E and M/C142/E	120-277	163	Studs	Top	13	1
188989*	M15012/27CK-5EU-JT3	150	M/C102 and M/C142	120/277	163/165	Studs	Top	13	2a, 2b, 2c
Mid Wattage									
188909*	M21020-27CK-2EUN-F	210	C183	208-277	227	Feet	Side	17	4a, 4b

*Exceeds EISA 2007 requirements with 90% efficiency.

Wiring Diagrams

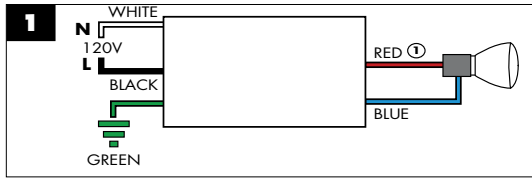

120/277V with IDTP Tap

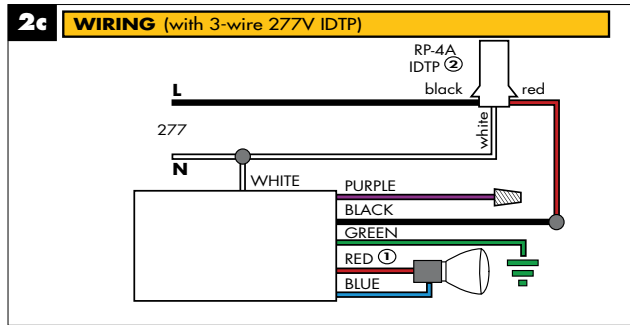
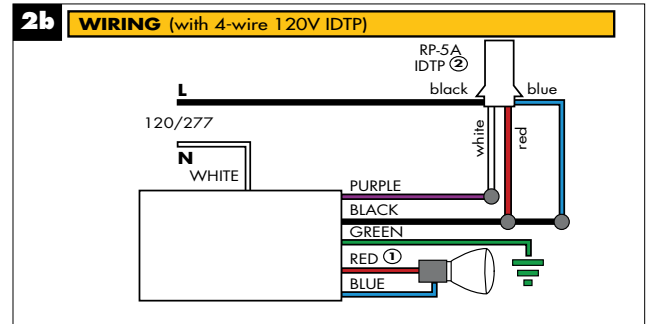
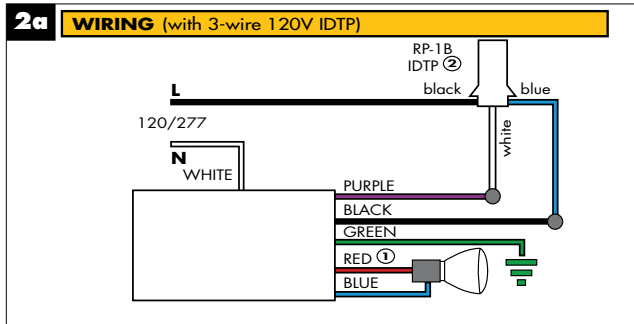

120/277V with Auxiliary Control + IDTP Tap

Wiring & Dimensions Diagrams (shown in millimeters and inches)

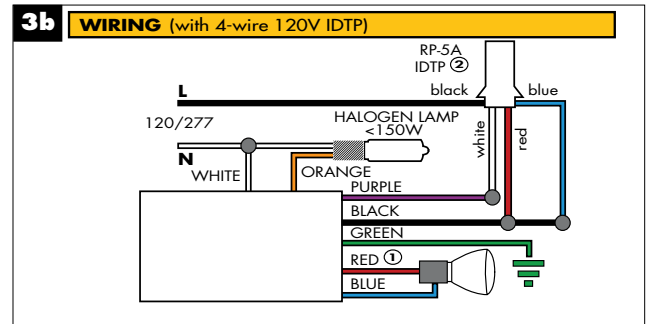
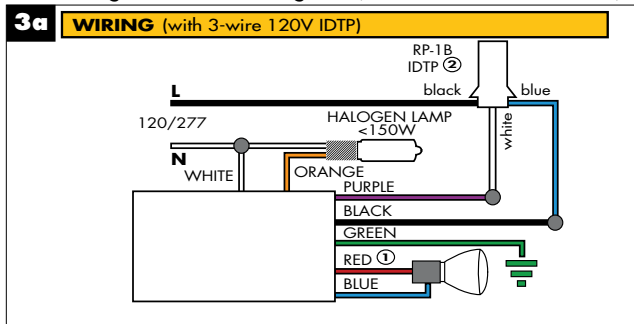

Notes for Wiring Diagram

- ① Connect red lead to center contact on Edison base lampholders
- ② IDTP - Insulation Detector Thermal Protector

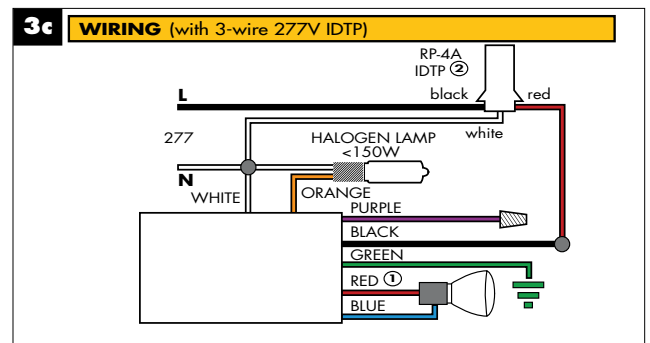

Dimming Ballasts

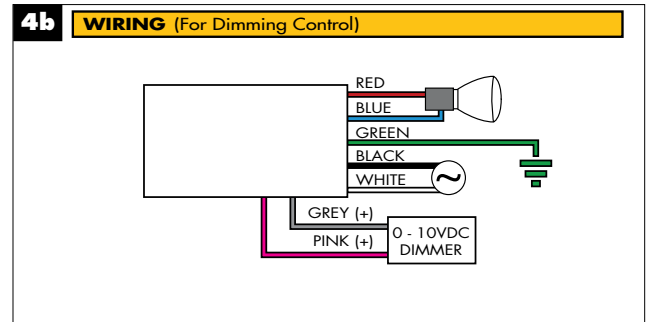
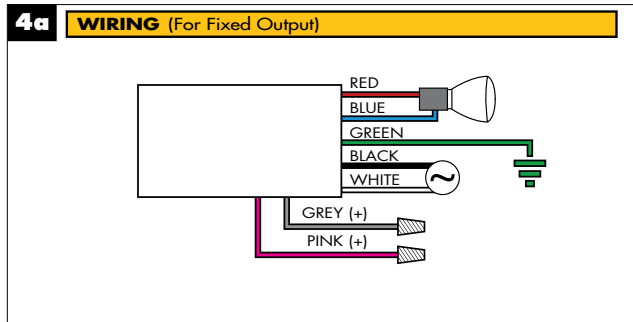

Dimensions

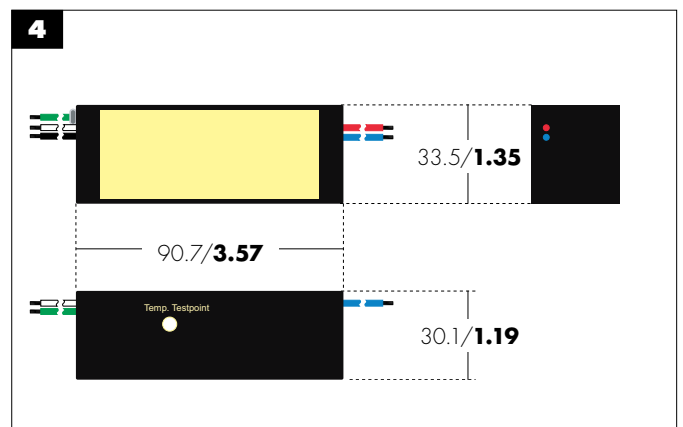
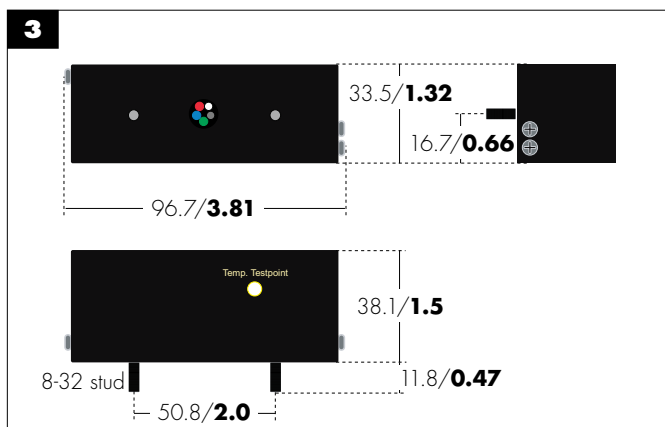
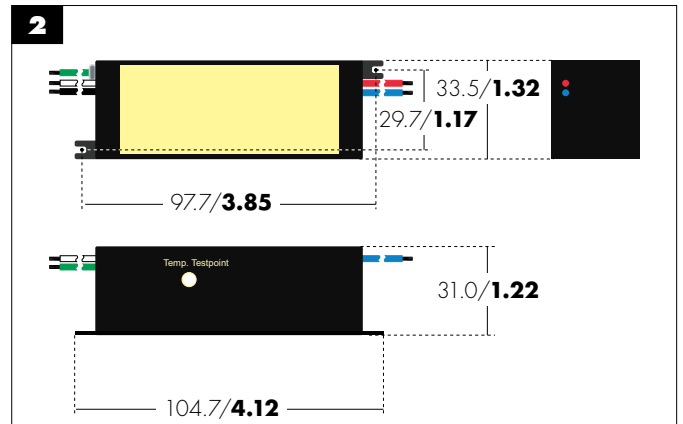
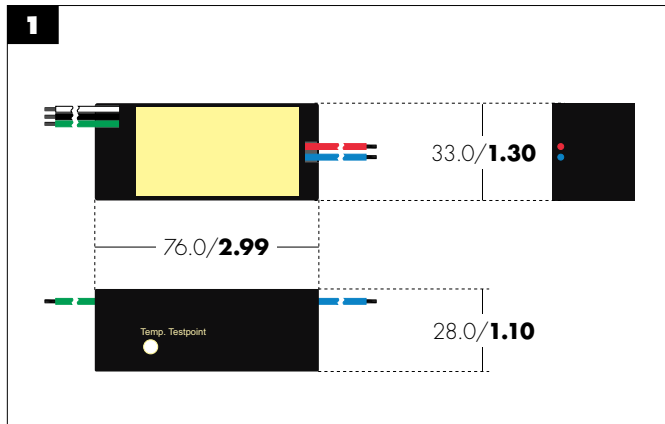

Dimensions

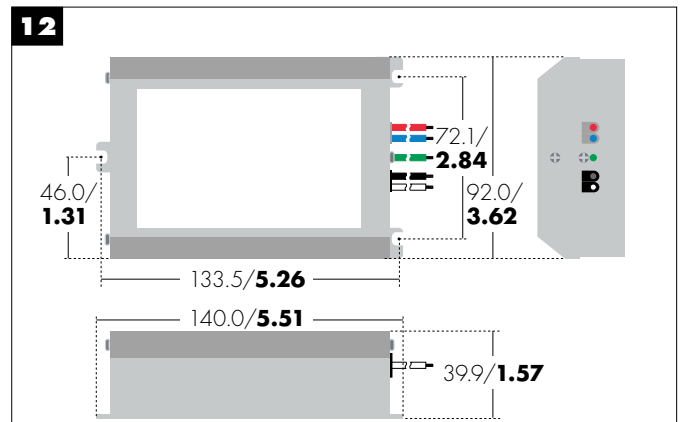
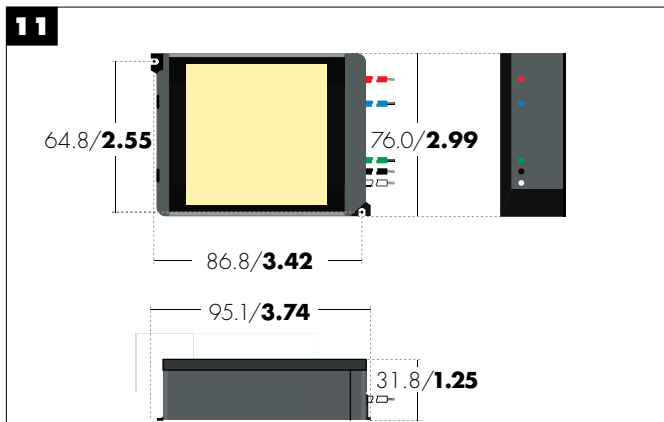
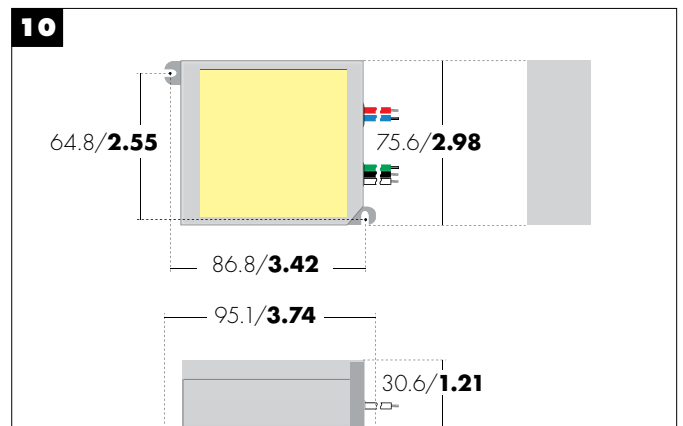
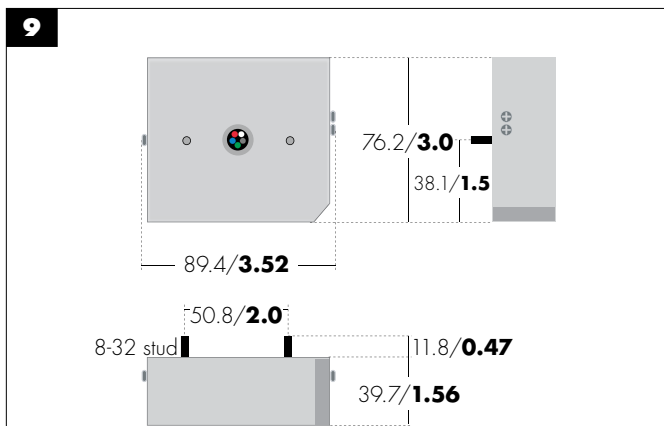
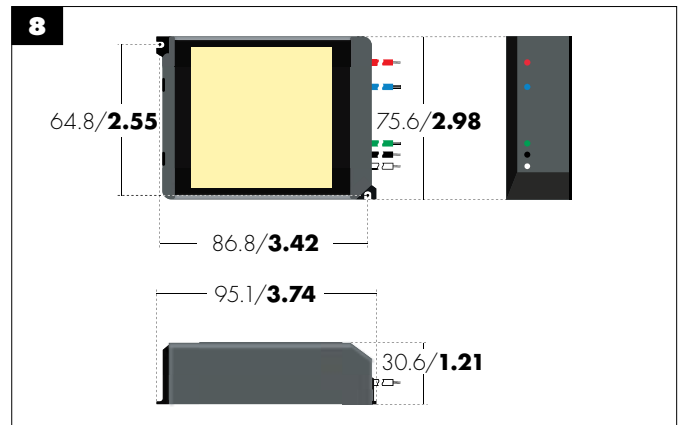
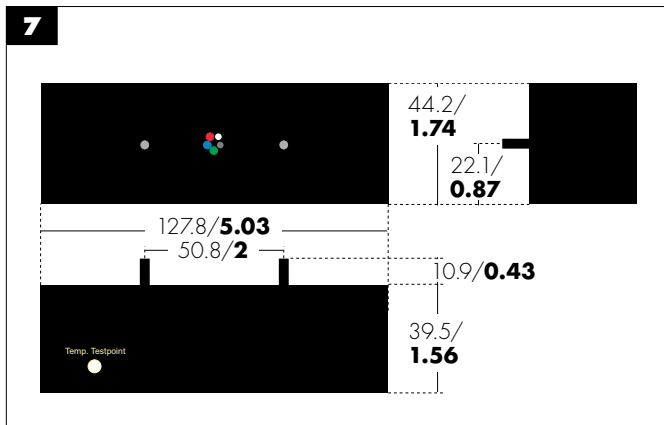
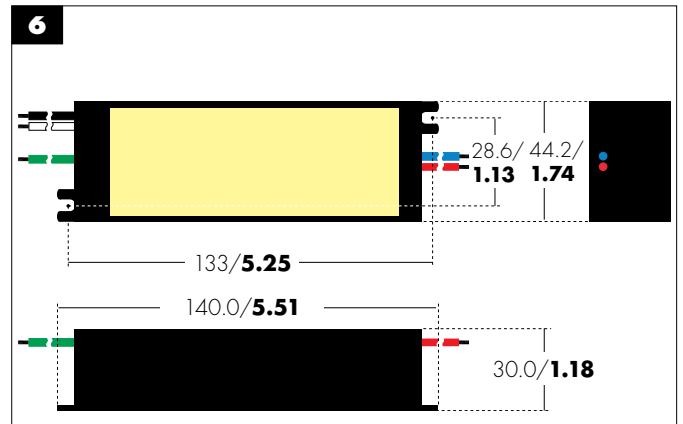
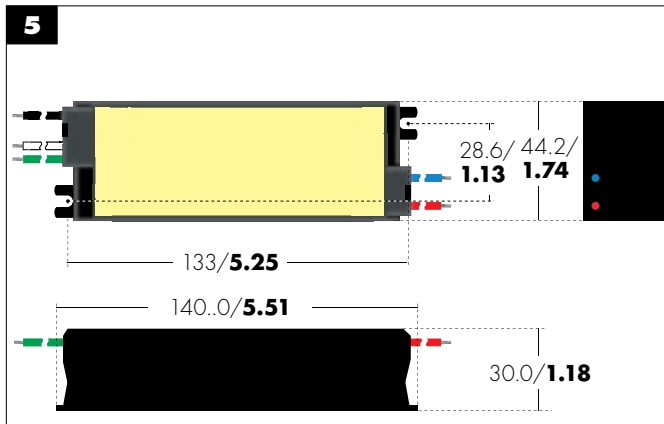

Dimensions

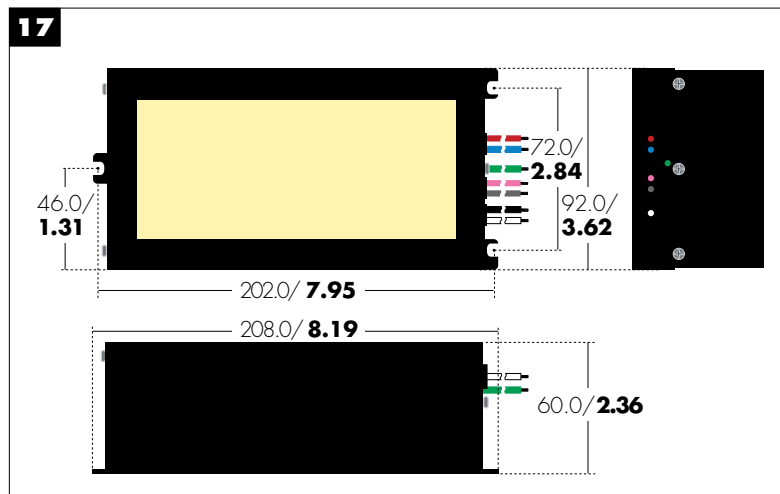
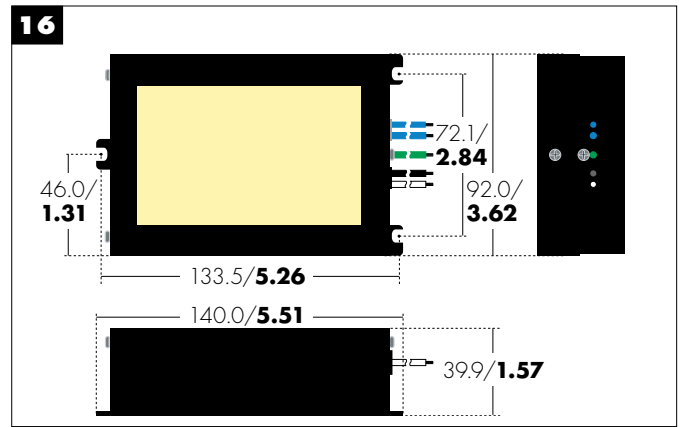
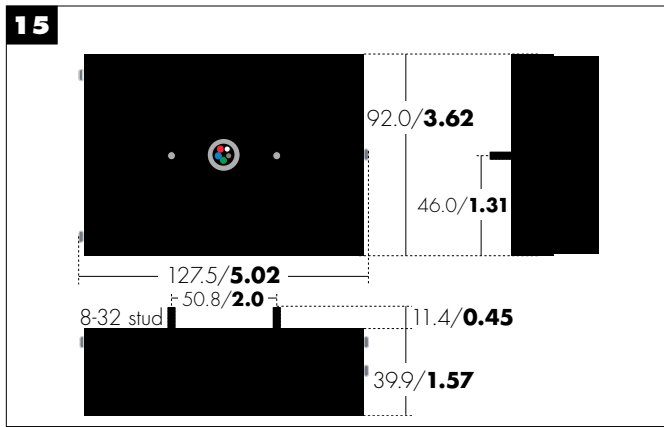
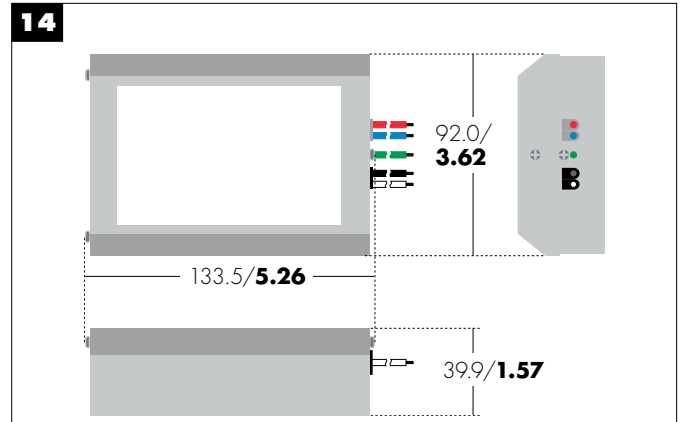
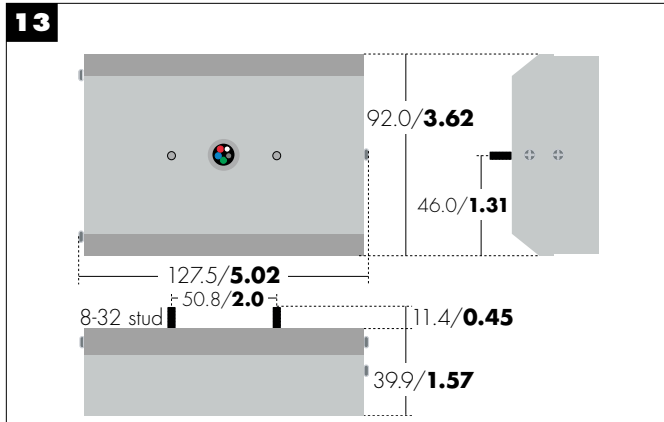

Application And Operating Information

General:

If the electrical current through an HID lamp is properly stabilized, an HID plasma arc with very high luminous efficiency is created in the arc tube chamber resulting in a very efficient light source. The internal pressure of the arc tube chamber rises as the arc tube temperature increases and will attain between 1 and 10 bar; thereby, defining these lamps as high-pressure HID lamps, high intensity discharge lamps or simply HID lamps. The light output and color rendition of HID lamps vary considerably depending on the lamp family (mercury, metal halide or sodium lamps).

HID lamps can only be started and operated with ballasts. Ignitors or ignition voltage characteristics are additionally required for sodium and metal halide lamps. As well as stabilizing the lamp's operating point, ballasts also influence the lamp's output and luminous flux, the system light output, the service life of the lamps as well as the color temperature of the light source.

Electromagnetic or electronic ballasts can be used for HID lamps, but unlike fluorescent lamps, lamp efficiency is not significantly improved by the use of electronic ballasts. However, electronic ballasts can lead to a reduction of the inherent losses and thus to an increase in system efficiency. In addition, electronic ballasts can ensure gentle lamp operation, which may increase lamp's service life.

Electronic Ballasts for Metal Halide Lamps

Electronic ballasts are designed with all the components required to operate metal halide lamps, including ignition, power factor correction, and stable normal operation. Furthermore, they safely shutdown lamps at the end of their service life to prevent high temperatures from being generated in the luminaires that could influence the service life of the luminaire or its components. Vossloh-Schwabe also provides special electronic ballasts for additional luminaire functions such as heater power for insulation detection thermal protectors and for switching on of an auxiliary incandescent lamp for the dark phase of an HID lamp during initial warm-up or during hot-restrike cool-down mode.

Standards/Regulations

ANSI C82.14 Low-Frequency Square Wave Electronic Ballasts for Metal Halide Lamps

UL 1598 Standard for Safety-Luminaires

ANSI C82.77 Harmonic Emission Limits-Related Power Quality Requirements or Lighting Equipment

ANSI/UL 1029 Standard for Safety-High Intensity HID Lamp Ballasts

ANSI/IEEE C62.41 Surge Voltages in Low Voltage AC Power Circuits

US Code of Federal Regulations Title 47 –Telecommunications Part 18– Industrial, Scientific and Medical Devices

Application And Operating Information

Technical Specifications:

Operating voltage range

120VAC rated: 120V 277V $\pm 10\%$

277VAC rated: 277V $\pm 10\%$

120–277V rated: 108V–305V

120/277V rated: 108V–132V and 249V–305V

Leakage current $\leq 0.5\text{mA}$

Hot restrike auxiliary lamp operation

In order to ensure continuous illumination even during the ignition period or in the event of a lamp drop-out due to short term power outage, an additional incandescent lamp (maximum 150W) can be used on models designated with a JA suffix.

Short circuit issues

The ballast output metal halide lamp leads are basically short-circuit-proof. However, any shorts or connections between those lamp leads to the ballast case or to safetyneutral (earth ground) will destroy the ballasts. Likewise the metal halide lamp leads shall not be connected to input power connections nor shall the auxiliary lamp leads be shorted together otherwise the ballast's circuitry could be damaged or fail.

Provisions in the luminaire design should be implemented to prevent all lead wires but especially lamp leads from being pinched, damaged, or cut during luminaire assembly, field installation or normal service.

Mechanical Mounting:

Surface

Firm, flat, preferably metal surface required to ensure good heat transfer for long ballast service life and reliability. Avoid mounting on uneven or protruding surfaces.

Mounting Location

Electronic ballasts must be protected against moisture and heat. Outdoor applications must utilize luminaires with the appropriate weatherproof ratings depending on location. Most Vossloh-Schwabe electronic ballasts are rated "Outdoor Type 1".

Fastening

Use mechanical means to ensure ballasts are fixed tightly to flat surfaces. Use appropriately sized screws depending on the ballast mounting slot size or spring clips to provide interference fit.

Heat transfer

If ballast is destined for installation in a luminaire, sufficient heat transfer must be ensured between the electronic ballast and the luminaire housing. Electronic ballasts should be mounted with the greatest possible clearance from heat sources or lamps. During operation, the temperature measured at the ballast's tc point must not exceed the specified maximum value.

Application And Operating Information

Technical Specifications:

- **Dimensional tolerances:**

- Case: $\pm 1\text{mm}$ ($\pm 0.039''$)
- Standard lead length tolerances: $+50\text{mm}$ ($+2''$) or -30mm ($-1''$) Micro lead length tolerances: $\pm 15\text{mm}$ ($\pm 0.6''$)
- Slot width on "F" mounting tabs: 5mm ($0.20''$); for Mini-Square Size: 4mm ($0.157''$)

- **Remote wiring guidelines:**

- Each lamp's lead wires must be run in a separate conduit from the input power leads to achieve good EMI performance and maximum remote capabilities. Lamp leads shall not be bundled together, but each set of lamp leads shall be run in its own conduit.
- Individual lamp lead wires must be used for external fixture wire extensions using wire types SF-2 (equivalent to SEW-2 or 3071) or SFF-2 (equivalent to SEWF-2 or 3070) or alternately, if approved by VS, high voltage luminaire wire with a 18AWG conductor and a 1000VAC minimum voltage rating. Temperature rating is especially critical if the lamp lead extension wires are directly connected to lampholder terminals.
- Maximum remote distances:
See individual model specification sheets.
The specified maximum remote distances are based on lamp leads run in a minimum $\frac{1}{2}''$ internal diameter conduit, pipe or flexible conduit. For longer remote distances contact the TES group at Universal Lighting.
- Using service power cords (types SJ, SO, ST, SV etc.) or metal clad cable assemblies for lamp lead extension wire are **not** recommended as they are not compatible with the above characteristics, can cause starting problems and shall not be used unless VS gives written approval.

Insulation clearance

Remote mounted ballasts shall be installed per National Electrical Code and local codes while also complying with wiring methods per Vossloh-Schwabe recommendations. Per UL requirements, thermal insulation shall be a minimum of 3" from any ballast surface.

Application And Operating Information

Safety Functions:

Regulatory approvals

Vossloh-Schwabe electronic HID ballasts are UL listed or UL recognized component and cUL listed for use in Canada.

Shutdown of defective lamps

In the event of a lamp failing to ignite or of a lamp with low or high operating voltages (end of lamp's service life), the electronic ballast will switch off after a defined period of time (typically 30 minutes). The ballast will also shut-down if the lamp fails to achieve symmetrical current operation (rectification) or if lamp leads are shorted to each other. After lamp replacement, the ballast output can be reset by disconnecting (count to 10) and then reconnecting input power.

Transient input voltage

Electronic ballasts incorporate transient protection that complies with ANSI C62.41 and ANSI C82.14 test procedure and values.

Temperature Protection

To prevent excess temperatures, ballasts contain thermal protection devices or thermal sensing circuitry. A ballast will restart after it has cooled down, however, it might be necessary to briefly reset the input power after the over-temperature condition is resolved.

General guidelines

Always disconnect power to the luminaire before installation or service of the ballasts. Install to all provisions of local or National Electric Codes. The ballast case/green lead must be grounded. Dispose of any replaced ballasts or lamps properly per local environmental regulations.

Reliability and Service Life:

The electronic ballast service life is inversely proportional to the temperature of its critical internal components. Normal ballast operation shall have the temperature of the tc point less than the warranted values in the individual specification sheets

Electrical Installation:

3-Phase connection of luminaires with electronic ballasts

Prior to operating newly installed lighting systems, please check the ballast's rated voltage range to ensure it is appropriate for the job site input power supply voltage. The neutral power supply wire must be connected securely to all luminaires and to all ballasts. Power supply conductors must only be connected or disconnected when the circuit is not energized. The neutral conductor must never be disconnected as the first disconnected wire nor individually at the circuit panel, at a distribution wiring junction box or at the luminaire during energized power supply operation as out-of balance voltage operation can lead to serious over-voltages and subsequent ballast failures.

Power factor compensation

Luminaires with electronic ballasts do not need power factor compensation, as the typical power factor range of electronic ballasts is 95 to 99%.

Application And Operating Information

Wiring

Wiring between the power supply, electronic ballasts and lamp must comply with the respective circuit diagram.

Note: the ballast (metal) case (using toothed washer) or provided green lead must be connected to safety-neutral (earth ground). In addition, all metal luminaire parts and metal lamp reflector/housings shall also be connected to earth ground for safety and for proper lamp starting. Metal halide luminaires must only be fitted with electrical components that are rated to withstand ignition voltages of 4kV. To ensure compliance with RFI suppression limits, input and output conductors should not be run in the same conduit as lamp conductors. Conduit size recommendations are stated in the individual ballast specification sheets or construction notes.

Lamp maintenance notice

To replace end-of-service lamps, turn-off luminaire power, remove and replace lamps then turn-on luminaire power. If power was not turned off during lamp replacement, the luminaire/ballast-input power must be reset to restart the new lamp. If the lamp or wiring is defective, the ballast will “shut-down” in 1.5 to 30 minutes depending upon the fault condition.

Supplemental IDTP wiring

The IDTP (insulation detector thermal protector) is required by UL for most recessed luminaires. This fast acting thermal protector is typically mounted on the same junction box as the electronic ballast. Special “JT” electronic ballasts provide a separate 120V power supply for the IDTP heater to allow the luminaire to be rated for both 120V and 277V operation. See the individual ballast specifications for the proper wiring procedures for JT & JA ballasts with this IDTP heater function.

Note: When using JT or JA ballasts on multiple lamp luminaires, only one ballast yellow or purple lead should be connected to the IDTP heater. All other ballasts’ yellow or purple leads should be capped-off. Operation of JT and JA ballasts on 208V and 240V is not recommended, as the IDTP may not function properly.

Lamp compatibility

Not all HID lamps are compatible with all electronic ballasts. Therefore, consult with Vossloh-Schwabe Technical Support or a specific lamp company regarding a certain lamp’s compatibility.