

Conference Room Lighting with Leviton DALI Controls and Universal Lighting Technologies DaliPro® Ballasts

One (1) Leviton CD250 DALI Controller

Wiring Details

Although power and control connections must be provided to each of the ballasts, the fixtures do not need to be wired as specific dimming groups. Dimming groups are established by programming procedures after all connections have been completed.

In the case of the Leviton DALI system, a single, non-polarized circuit is wired to link all ballasts, the CD100 power supply and the CD250 wall control. This may be wired as either a Class 1 or Class 2 circuit, as long as local codes are followed and the class of wiring is consistent throughout the system. See the figure below for an example of how the sample conference room could be wired using controls from Leviton.

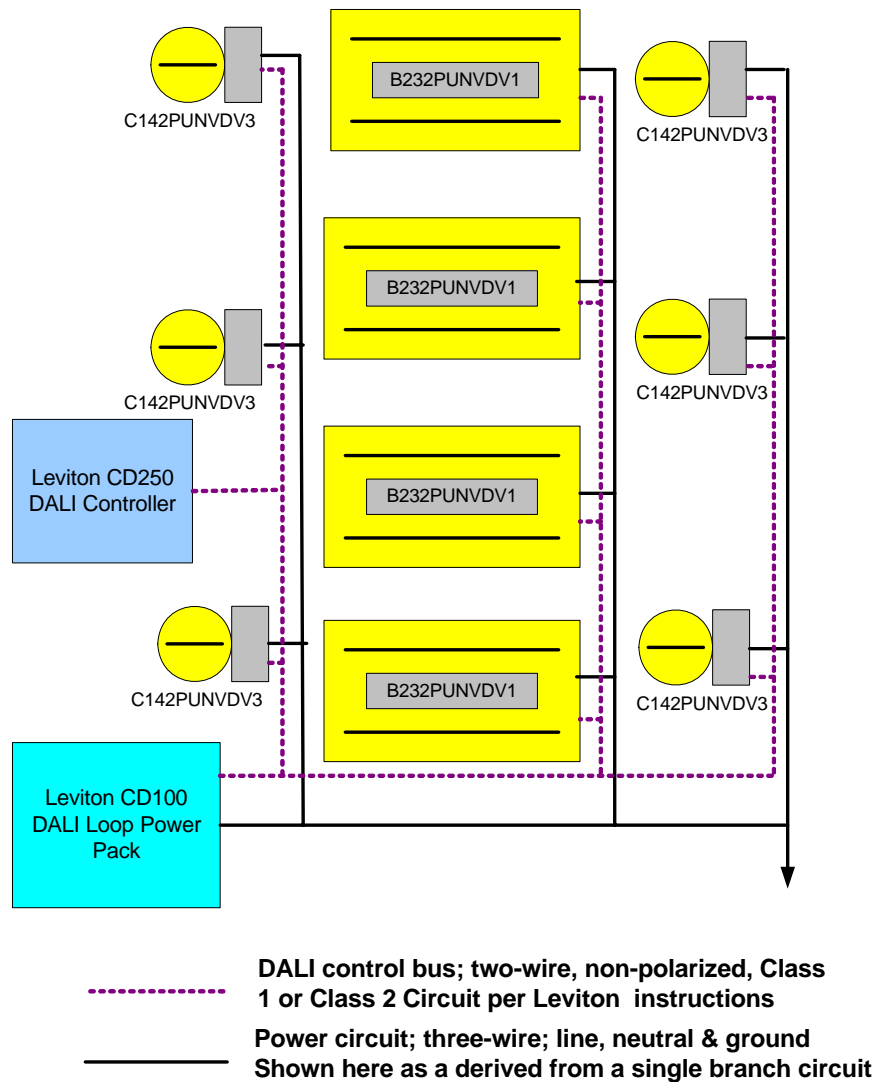

Fig.1

The figure below provides power and control connection details for the Universal Lighting Technologies DALI ballasts. Please refer to materials provided by Leviton for detailed wiring instructions for the Leviton CD100 and CD250 products.

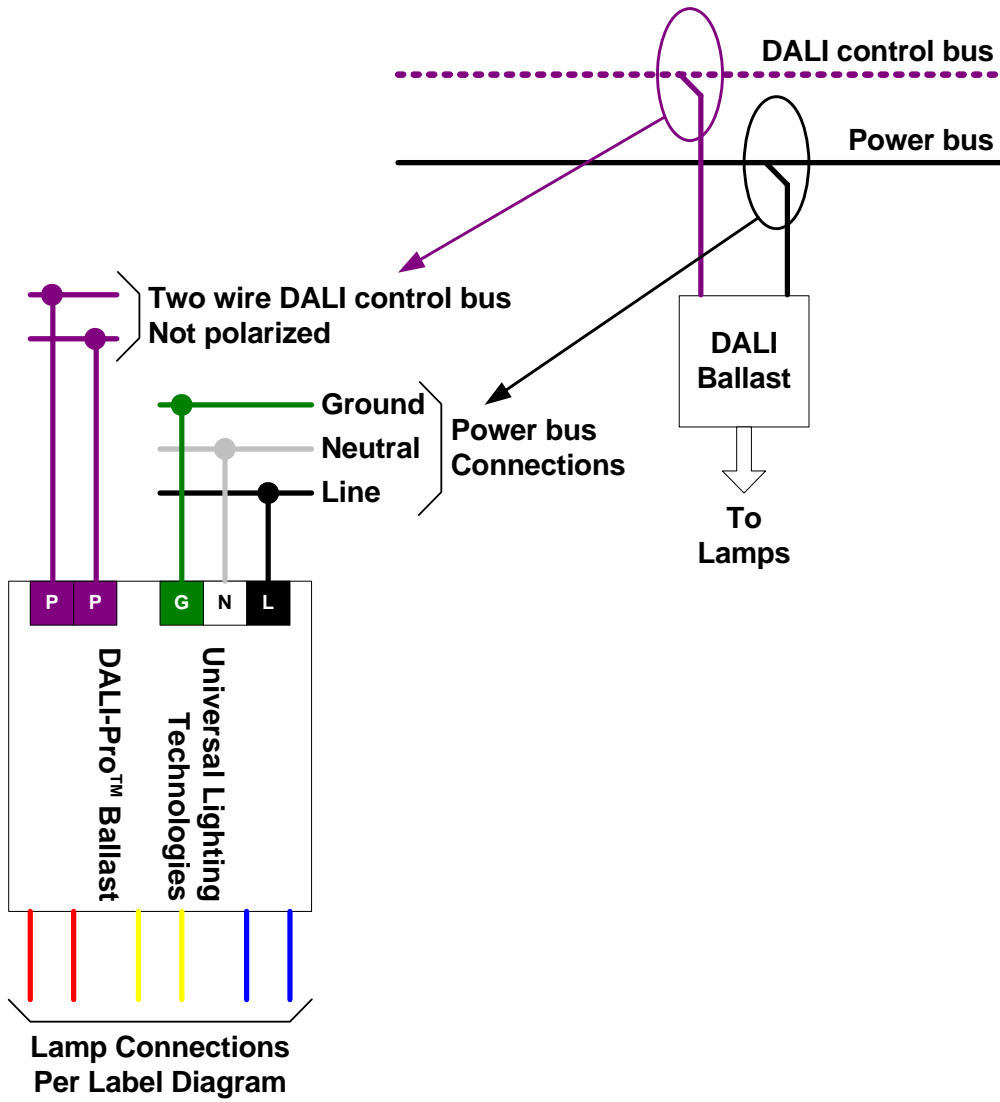

Fig.2

The Leviton CD250 DALI Controller

The Leviton CD250 can be configured as a group or scene controller. Group control permits independent control (on, off, up or down) of up to four, user-defined fixture groups. Scene recall mode allows selection of up to eight user-defined lighting scenes.

Because this control can be configured for group OR scene control, but not both simultaneously, it comes with two, replaceable faceplates – one for each mode.

Both faceplates have a series of buttons for user input and LEDs for selection/status indication. Different markings are used to distinguish between them as shown below. Please refer to the materials provided with the Leviton CD250 for specific steps on how to remove and replace the faceplates.

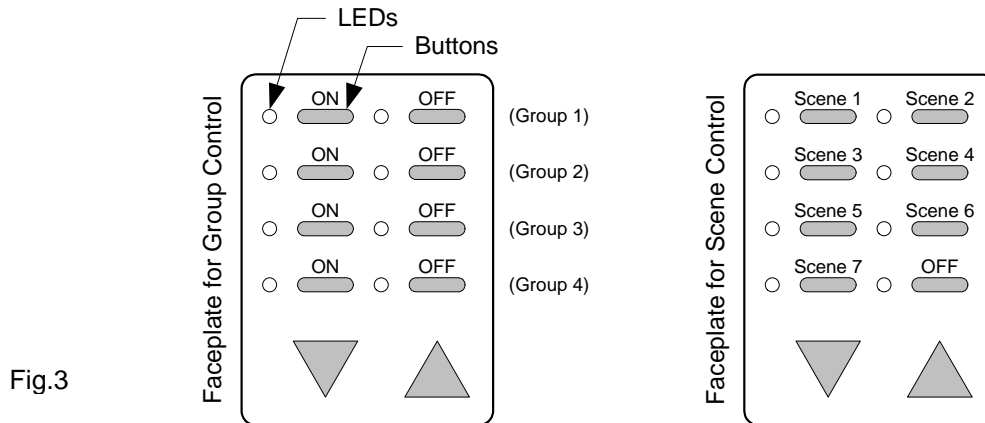

Fig.3

Behind the removable faceplate there is a collection of (8) buttons for programming and operation, and a group of (8) fiber optic rods through which the light from the LEDs is normally brought to the faceplates. These are marked 0 – 7 in the illustration below.

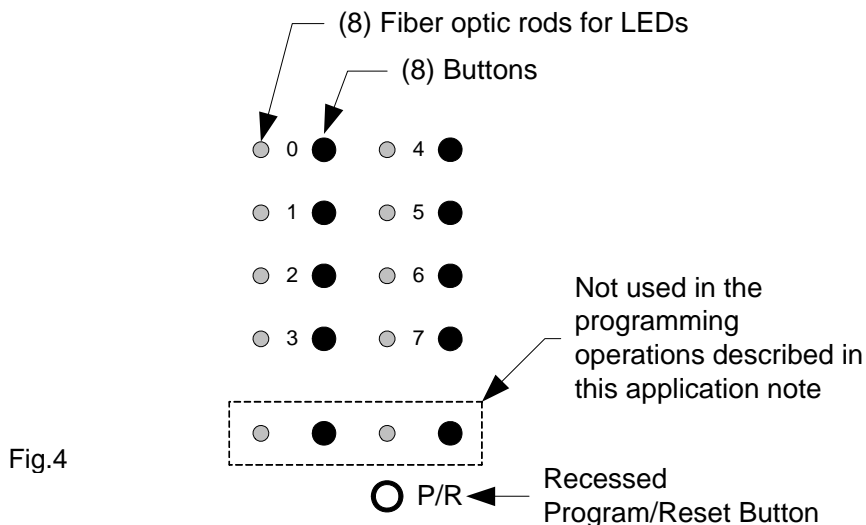

Fig.4

There is also a recessed button, labeled 'P/R' on the diagram.

The two LEDs and two buttons within the dotted line are not used for the programming options discussed in this application note.

Before the group control or scene recall modes can be properly used, group and/or scene programming must be completed.

Programming Overview

Group and scene programming, using the Leviton CD250 DALI Controller is accomplished by a series of easy, and logical, processes. The basic sequences are outlined directly below. Detailed instructions are provided in a later section, and in materials provided with the Leviton controls.

GROUP PROGRAMMING

1. Reset ballast addresses
2. Define CD250 as a group mode controller
3. Assign ballasts to groups
4. Exit programming mode

Once the group programming steps are completed, the buttons on the group control faceplate can be used to control the defined groups.

SCENE PROGRAMMING

Note: Group programming must be completed before starting the scene programming sequence.

1. Define the CD250 as a group mode controller
2. Use the group mode control buttons to establish a desired lighting appearance
3. Define the CD250 as a scene mode controller
4. Store the desired lighting appearance as a lighting scene
5. Repeat steps 1 – 4 for a total of up to eight scenes

Once the scene programming steps are completed, the buttons on the scene control faceplate can be used to recall the stored scenes.

Also, because multiple Leviton CD250 controllers can be connected to the same DALI loop, the iterative nature of the SCENE PROGRAMMING steps outline above can be reduced by connecting two devices and defining one as a group mode controller and the other as a scene mode controller.

Programming Objectives

It is always best to start a programming sequence with a specific result identified as the objective.

For purposes of illustration, the programming objectives of this example are to assign fixtures to groups as identified in the figure 5, and to create and store scenes as described in the accompanying table. Note that in the case of the Leviton CD250, ballasts can be assigned to any or all of the four groups. In the example shown, all ballasts are in Group 1.

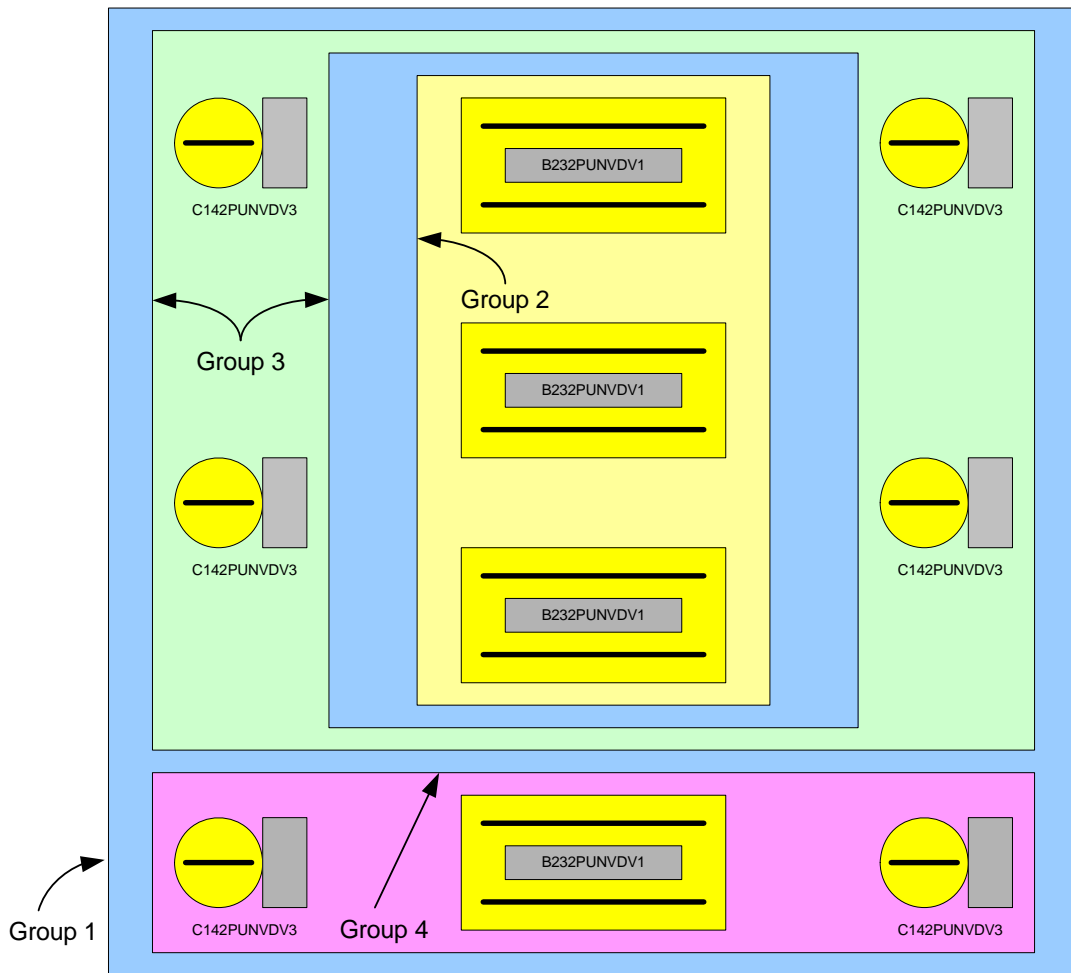

Fig.5

Scene No.	Scene Name	Description
1	Maintenance	All ON, Group 1 at full bright
2	Presentation	Groups 4 OFF; Groups 2 & 3 ON at about ½ bright
3	Meeting	Groups 3 and 4 OFF; Group 2 ON full bright
4	Meeting 2	All ON, Group 1 at 75%
5		User TBD
6		User TBD
7		User TBD
8	OFF	All OFF

Detailed Programming Instructions

The following paragraphs describe steps needed to commission a small room equipped with Universal Lighting Technologies DALI ballasts and the Leviton CD250 DALI Controller. Please obtain technical information from Leviton for a more detailed description of these procedures.

Because the Leviton CD250 has many capabilities it generally requires two steps per programming operation: one to define the control mode of the CD250 (this is called programming mode A [PMA] in the Leviton instructions) and another to perform the specific group or scene assignment (this is called programming mode B [PMB]). The recessed P/R button, accessible with a small diameter object (like a bent paper clip), is used to toggle the CD250 between programming modes.

Finally, during the operation and programming sequences described below, each of the (8) programming LEDs can either be lit (not flashing), lit and flashing, or unlit. These states are used for programming and must be recognized as different from one another. When in programming mode A [PMA] pressing the button next to a programming LED should cause it to toggle between lit and lit and flashing.

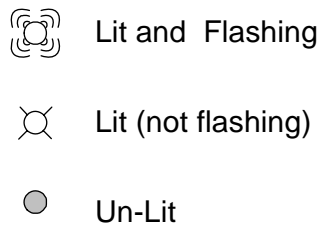

Fig.6

GROUP PROGRAMMING

1. Reset ballast addresses

- Observe the (8) programming LEDs. If any are lit and flashing, or if all are lit, the CD250 is in a programming mode already. In this case momentarily press and release the P/R button to exit the unknown programming mode. Now all (or most) LEDs should be unlit.
- Momentarily press and release the P/R button to enter programming mode A [PMA]. All programming LEDs should be lit or lit and flashing.
- Press and release the buttons adjacent to any lit (not flashing) LEDs until all (8) are lit and flashing (this corresponds to the non-scene individual mode described in the Leviton instructions)

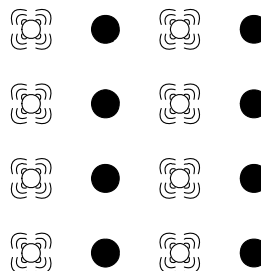

Fig.7

- Press and release the P/R button to exit PMA.
- Press and hold the P/R button for 15 seconds. The DALI ballasts and programming LEDs on the CD250 go through a preprogrammed sequence. At the end of the 15 seconds, the ballasts should all be on at full bright, and all (8) programming LEDs should be unlit. The ballast addresses are now reset and ready for group programming.

2. Define CD250 as a group mode controller

- a. Observe the (8) programming LEDs. If any are lit and flashing, or if all are lit, the CD250 is in a programming mode already. In this case momentarily press and release the P/R button to exit the unknown programming mode. Now all (or most) LEDs should be unlit.
- b. Momentarily press and release the P/R button to enter programming mode A [PMA]. All programming LEDs should be lit or lit and flashing.
- c. Press and release the buttons adjacent to the LEDs until the pattern shown below is achieved. This corresponds to the non-scene group mode described in the Leviton instructions.

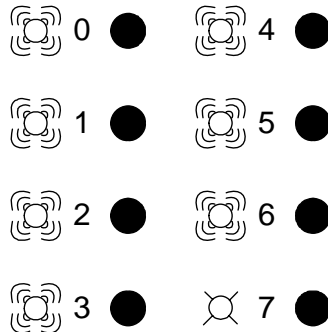

Fig.8

- d. Press and release the P/R button to exit PMA

3. Assign ballasts to groups

- a. Observe the (8) programming LEDs. If any are lit and flashing, or if all are lit, the CD250 is in a programming mode already. In this case momentarily press and release the P/R button to exit the unknown programming mode. Now all (or most) LEDs should be unlit.
- b. Press and hold the P/R button for about 7 seconds to enter programming mode B [PMB]. During the 7 seconds the (8) programming LEDs will exhibit the following characteristic sequence: first, after about 3 seconds the LEDs will light in horizontal pairs, rolling from top to bottom; then, after a couple of cycles the LEDs will light in alternating columns. Release the P/R button at this time. At this point, one and only one of the DALI ballasts should be ON at full bright. The others should be ON at minimum output.
- c. Note which ballast is at full bright and determine which groups it will be assigned to.
- d. Because the CD250 allows ballasts to be in more than one group it is necessary to indicate whether the ballast is 'in' or 'not in' each of the four available groups. A button on the left hand column indicates that the ballast is in the selected group. For example, to indicate that the ballast is in both groups 1 and 4, press buttons '0', '5', '6' and '3', indicating that the ballast is: 'in group 1', 'not in group 2', 'not in group 3' and 'in group 4' respectively. See below – LEDs not shown for clarity.

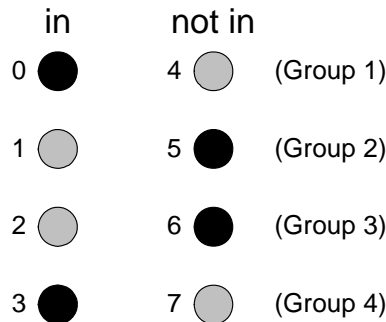

Fig.9

After a selection (in or not-in) has been made for each group, this ballast will go to minimum output and a new ballast will go to full bright.

- e. Repeat the step above until all ballasts have been given their group assignments. When the last ballast has been assigned the CD250 will automatically exit programming mode B [PMB]. If it is necessary to exit PMB before group programming is complete, momentarily press and release the P/R button.

GROUP CONTROL

1. Define the CD250 as a group mode controller.

- a. Perform steps 2.a. through 2.d. of the GROUP PROGRAMMING instructions.

Note: if no programming has been done since performing the GROUP PROGRAMMING instructions, the controller is already configured as a group mode controller and this step is not necessary.

2. Turn groups on or off

- a. Press and release the appropriate button – see figure below

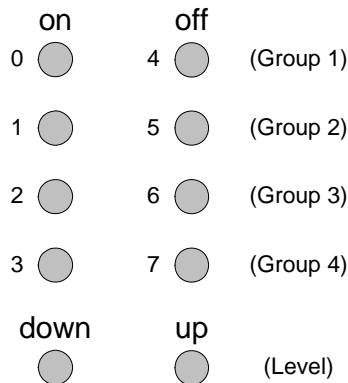

Fig.10

3. Adjust the light level of any group

- a. Turn the selected group ON
- b. Press and hold the down or up button – see figure above.
- 4. If the CD250 is to remain configured as a group mode controller ...
 - a. Install the group control faceplate as described in a previous section.

SCENE PROGRAMMING

1. Create desired lighting scene

- a. Perform GROUP CONTROL, as described above, to adjust all groups to the necessary light levels for the required scene.

2. Define CD250 as a scene mode controller

- a. Observe the (8) programming LEDs. If any are lit and flashing, or if all are lit, the CD250 is in a programming mode already. In this case momentarily press and release the P/R button to exit the unknown programming mode. Now all (or most) LEDs should be unlit.
- b. Momentarily press and release the P/R button to enter programming mode A [PMA]. All programming LEDs should be lit or lit and flashing.
- c. Press and release the buttons adjacent to the LEDs until the pattern shown below is achieved. This corresponds to the scene mode (described in the Leviton instructions as scene broadcast mode).

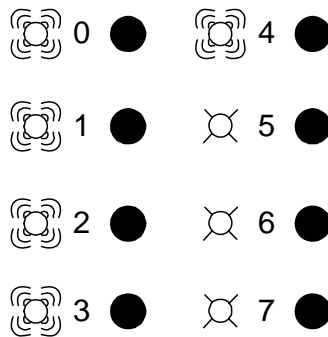

Fig.11

- d. Press and release the P/R button to exit PMA
3. Store scene to desired scene button
 - a. Observe the (8) programming LEDs. If any are lit and flashing, or if all are lit, the CD250 is in a programming mode already. In this case momentarily press and release the P/R button to exit the unknown programming mode. Now all (or most) LEDs should be unlit.
 - b. Press and hold the P/R button for about 7 seconds to enter programming mode B [PMB]. During the 7 seconds the (8) programming LEDs will exhibit the following characteristic sequence: first, after about 3 seconds the LEDs will light in horizontal pairs, rolling from top to bottom; then, after a couple of cycles the LEDs will light in alternating columns. Release the P/R button at this time.
 - c. Press and release the button to which you want the scene assigned.
 - Note: the reference numbers for the LEDs & program-buttons (shown on the programming diagrams) do not correspond to the scene-button numbers provided on the scene control faceplate.
 - The CD250 will automatically exit PMB and enter the scene control mode upon scene assignment.
4. If more scene assignments need to be made, repeat steps 1-3.
5. Install the scene control faceplate as described in a previous section.

SCENE CONTROL

1. Define the CD250 as a scene mode controller.

Perform steps 2.a. through 2.d. of the SCENE PROGRAMMING instructions.

Note: if no programming has been done since performing the SCENE PROGRAMMING instructions, the controller is already configured as a scene mode controller and this step is not necessary.

2. Press and release the appropriate scene button to recall a stored scene.

The light levels of all lit ballasts can be adjusted simultaneously with the DOWN and UP buttons.

WHERE TO OBTAIN HELP

For further information regarding Leviton DALI controls, visit their website at www.Leviton.com or call 1-800-824-3005.