

## Small conference room lighting with Universal Lighting Technologies DaliPro<sup>®</sup> ballasts

Digital Addressable Lighting Interface Technology (DALI) is an industry standard protocol for digital communications between lighting ballasts and a variety of lighting controllers as well as building management software. With DALI systems, each ballast can have its own unique address that allows for flexibility in programming scenes and simplicity with the initial wiring.

### Sample Application

A small conference room (Fig. 1) with ten lighting fixtures, comprising four (4) two-lamp F32T8 troffers and six (6) one-lamp, 42W CFL recessed down-lights.

The room is approximately square, and has three rows of fixtures – one row of troffers in the middle and a row of down-lights on either side.

There is a large window at one end of the rows of fixtures, and a projection screen on the other. The door is in a corner on the end with the projection screen.

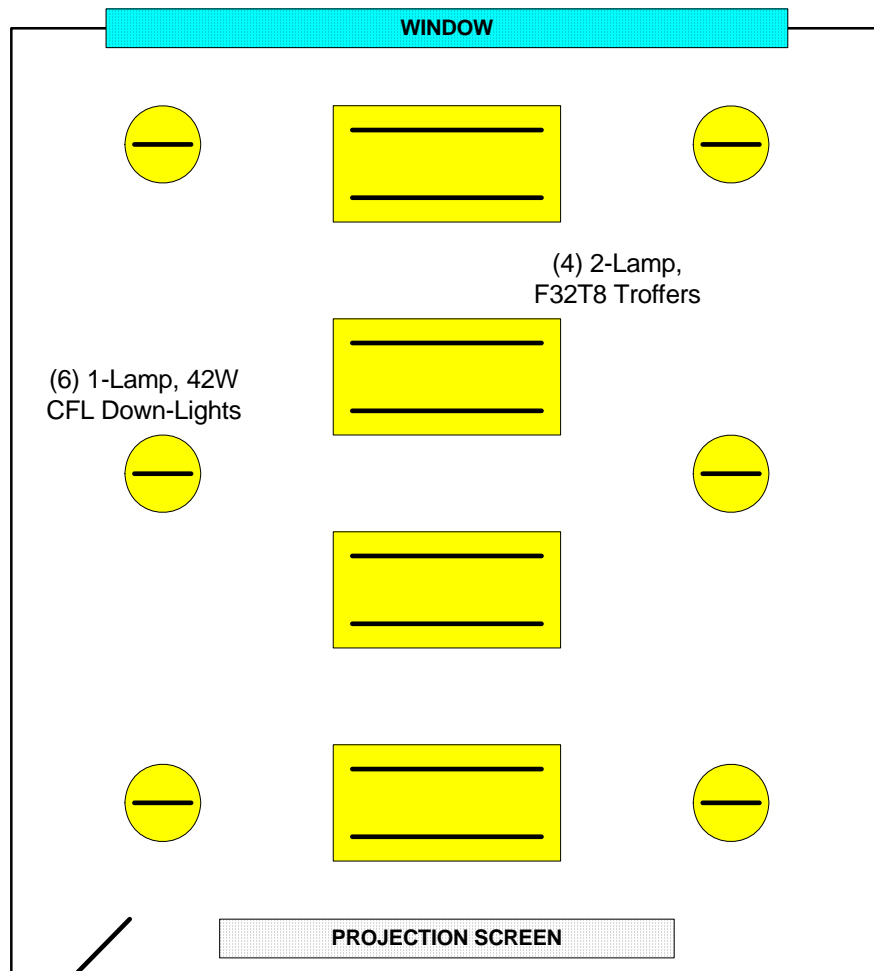

Fig. 1

**Required DALI Ballasts:**

Four (4) B232PUNVDV1, for the troffers, and six (6) C142PUNVDV3 for the recessed down-lights.

**Required DALI Controls:**

Required controls include one (1) DALI power supply, and one (1) DALI wall-station. Several control options are available, including devices from The Watt Stopper, Leviton, Starfield Controls and other manufacturers.

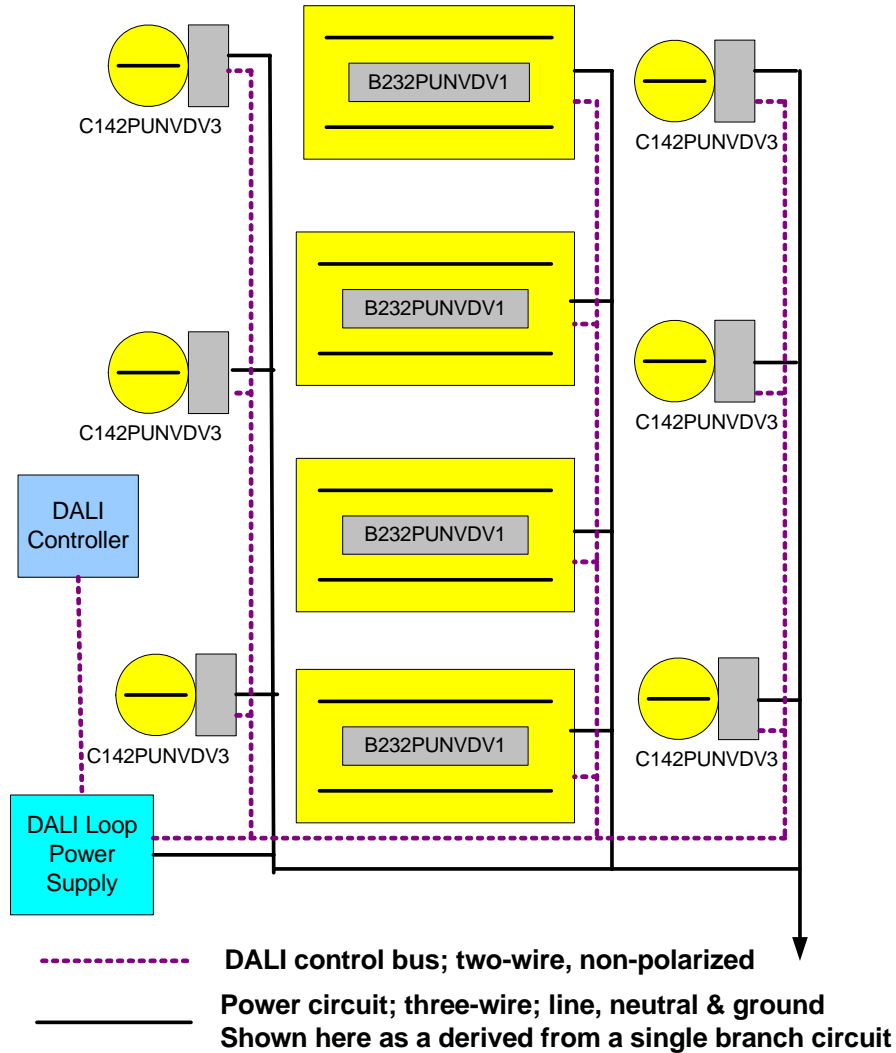

Fig. 2

**Control Wiring:**

Ballast control wiring comprises a two-wire, non-polarized circuit. Since programming assigns ballasts to specific groups, all ballasts can be connected to the same control wires and power circuit. DALI-Pro® ballasts are listed for either Class 1 or for Class 2 control circuit wiring but the selected method must be compatible with the ratings of the selected controls devices. Please refer to the specific installation instructions provided by the chosen controls manufacturer for this information. Attention must also be paid to the

proper class wiring between the power supply and DALI controller as this may be different than the rest of the control loop for specific control manufacturers.

### **Ballast Installation:**

Ballast mechanical installation, power wiring and lamp wiring procedures are similar to those for most dimming ballasts. It is important to ensure that the following requirements are met:

- Ballast and fixture chassis must be properly grounded
- Rapid sockets (non-shunted sockets) must be used for all lamp connections
- Lamp wiring diagrams (on ballast labels) must be carefully followed

The figure below provides power and control connection details for the Universal Lighting Technologies DALI ballasts. Please refer to materials provided the control manufacturer for detailed wiring instructions for the control.

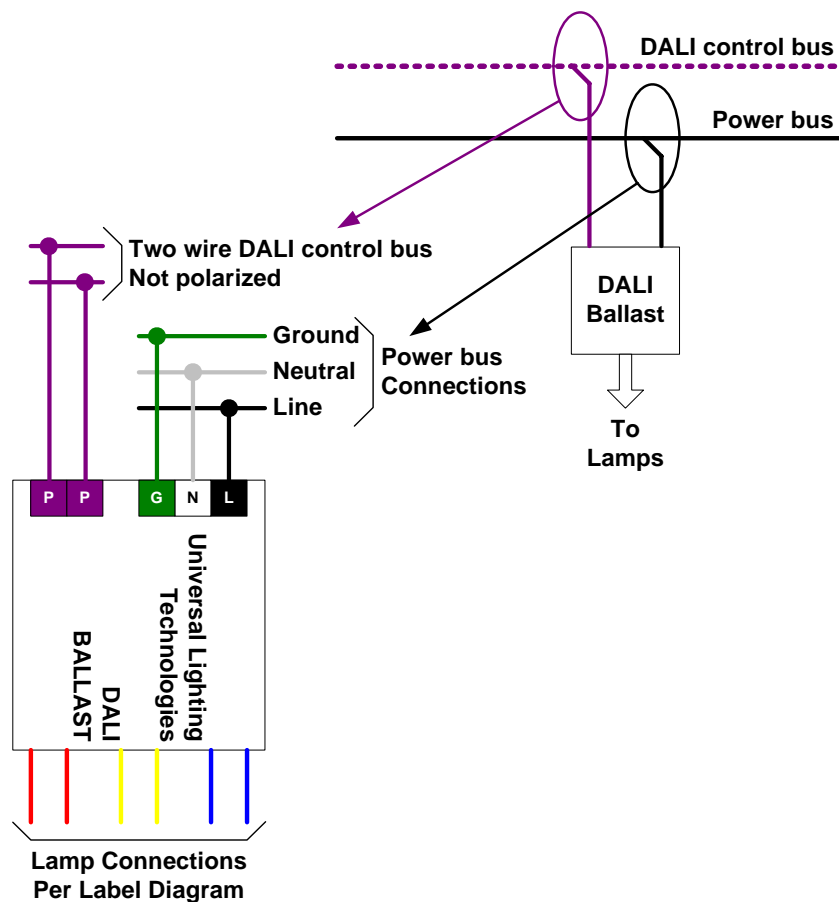

Fig. 3

## Programming Objectives

It is always best to start a programming sequence with a specific result identified as the objective.

For purposes of illustration, the programming objectives of this example are to assign fixtures to groups as identified in the figure on the following page, and to create and store scenes as described in the accompanying table.

Group and scene programming varies depending on the wall control being used. However, the general procedure involves the same generic steps.

## GROUP PROGRAMMING

1. Prepare for programming by pre-determining the group assignments
2. Assign ballasts to groups

## SCENE PROGRAMMING

Note: Group programming must be completed before starting the scene programming sequence.

1. Establish a desired lighting appearance
2. Save the desired appearance as a lighting scene

Repeat steps 1 & 2 for additional scenes. The maximum number of scenes is dependent on the controller

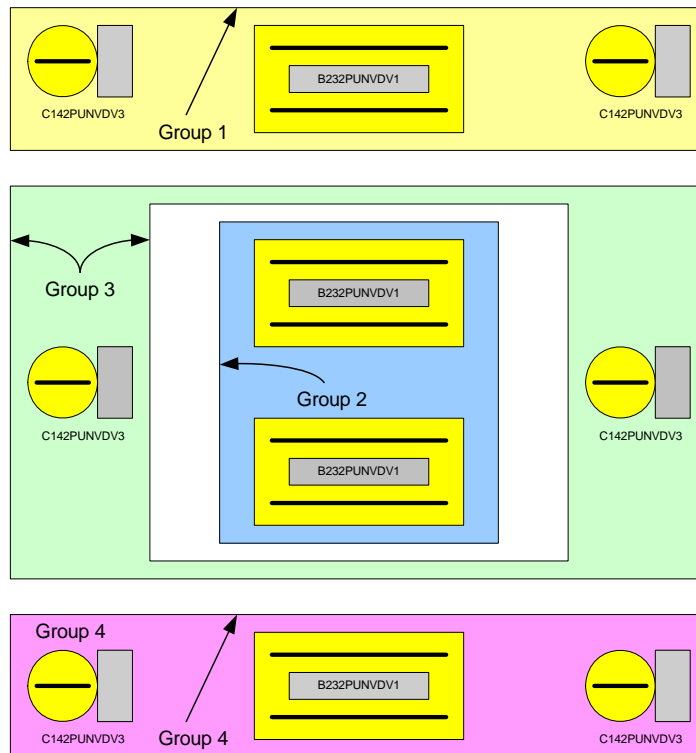

**Lighting Group Layout Example**

Fig. 4

## Scene Schedule

Scene No.	Scene Name	Description
1	Maintenance	All ON, full bright
2	Presentation	Groups 2 and 4 OFF; Groups 1 & 3 ON at about ½ bright
3	Meeting	Groups 1, 3 and 4 OFF; Group 2 ON full bright
4	Daylight	Group 1 OFF; Groups 2 & 3 ON at about ½ bright; Group 4 ON full bright

### Lighting Scene Example

#### **Additional Information:**

For additional information for use in programming either the Watt Stopper ezDALI Group and Scene Controller or the Leviton CD250 DALI Controller, please view our application notes within the Tech Support section of our website at [www.universalballast.com](http://www.universalballast.com).

Additional information for Universal's line of DALI-Pro® ballasts is available in the Dimming & Controls section accessible from the homepage at [www.universalballast.com](http://www.universalballast.com).