

SuperDim® System Installation

Warning! All SuperDim® devices are to be installed according to the label diagram and national and local building codes.

Mounting

- ❑ SuperDim® ballasts and modules must be mounted properly against a flat metal piece, which acts as a heat sink for the unit.
- ❑ Use a star washer or other paint penetrating device.
- ❑ SuperDim® Ballasts cannot be remote mounted or tandem wired.
- ❑ Lead lengths must be limited to the maximum values provided on the ballast labels or ballast specification sheets.
- ❑ The fixtures used to mount SuperDim® ballasts and modules must have an internal ambient temperature <40°C.
- ❑ Fluorescent fixtures cannot be mounted in an area allows drafts (causes dimming due to airflow).
- ❑ Linear lamp fixtures must incorporate a grounded lamp 'Starting aid'.
- ❑ Linear lamp to starting aid (Grounded Fixture Surface) spacing must be 1/8 to 1/2 inch.
- ❑ Lamps must not touch any grounded metal.
- ❑ Lamp support brackets (if any) must not be metal.

SuperDim® System Wiring

CAUTION!!!: Be fore installing or troubleshooting any SuperDim® components turn off AC power to prevent possible electric shock and unit damage.

Power Wiring

- ❑ If the SuperDim® ballasts are using the switched line from a control device, the maximum number of units depends on the current carrying capacity of the switch.
- ❑ Both SuperDim® components and light fixtures must be properly grounded, failure will result in lamp flickering and system malfunctioning.
- ❑ Ballasts must be securely grounded to grounded fixtures for proper operation.
- ❑ Make the required connections and cap off the unused wires (if any) with approved wire connectors.

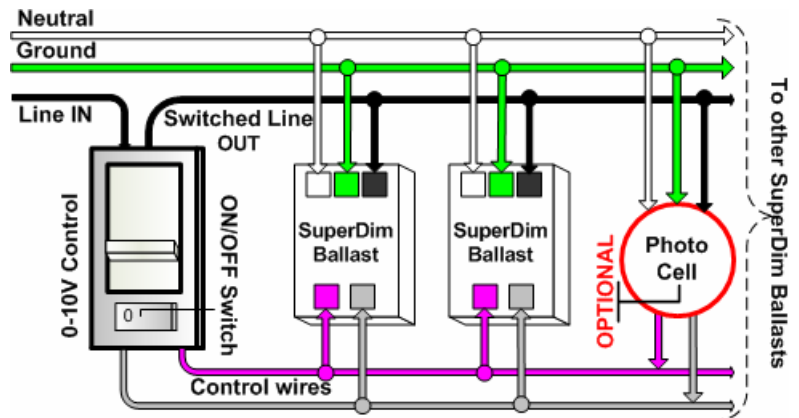

Fig 1. SuperDim Wiring Diagram

Control Wiring

- ❑ Do not connect the control wires to power.
- ❑ Never ground any of the control wires. This will cause intermittent operation of SuperDim® system.
- ❑ Polarity of control wiring is critical throughout the whole system for proper operation (Purple-to-purple & gray-to-gray).

Lamp Wiring

- ❑ Ballast to lamp wiring diagrams are shown on the ballast label. These diagrams must be adhered to for proper lamp and ballast operation.
- ❑ Keep the lead length **AS SHORT AS POSSIBLE** (Do not bundle).
- ❑ Always consistently wire (lead lengths) all fixtures in a room to avoid uneven light levels.
- ❑ Operate new lamps at full bright for at least 12 hours before dimming.
- ❑ Always use same type of lamps throughout the room to avoid uneven light levels.
- ❑ Never use shunted or instant start lamp sockets with SuperDim® fixtures (see Fig 2).
- ❑ Always use correctly rated lamp sockets.

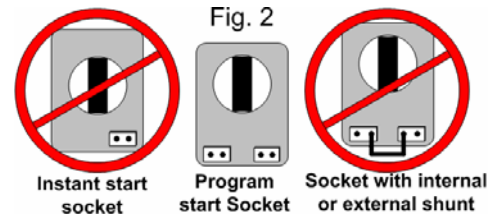

Installations resulting in twisted, folded or bundled lamp wires, and applications routing lamp wires in very narrow channels, should be validated by test. This test should be conducted at the target input voltage, and at both the maximum and minimum intensity levels. Test criteria should include acceptable starting performance with cold lamps as well as steady and uniform illumination during and after stabilization of the lamp temperature.

For further assistance or ordering information please contact Universal lighting technologies @ 1-800-BALLAST or visit our website at <http://www.universalballast.com>